

# **PIU** PICK UP UNIT



**Amazing Speed  
Shockless Mechanism**

***MACHINE ENGINEERING CORPORATION***

# Fastest operation 0.03 seconds/1 cycle

By combining advanced cam mechanisms accumulated over many years with reliable pneumatic equipment technology, we softly pick up delicate micro workpieces that are vulnerable to shock at ultra-high speed. The transfer of micro workpieces—previously considered inherently unstable—is solved by our proprietary mechanism.

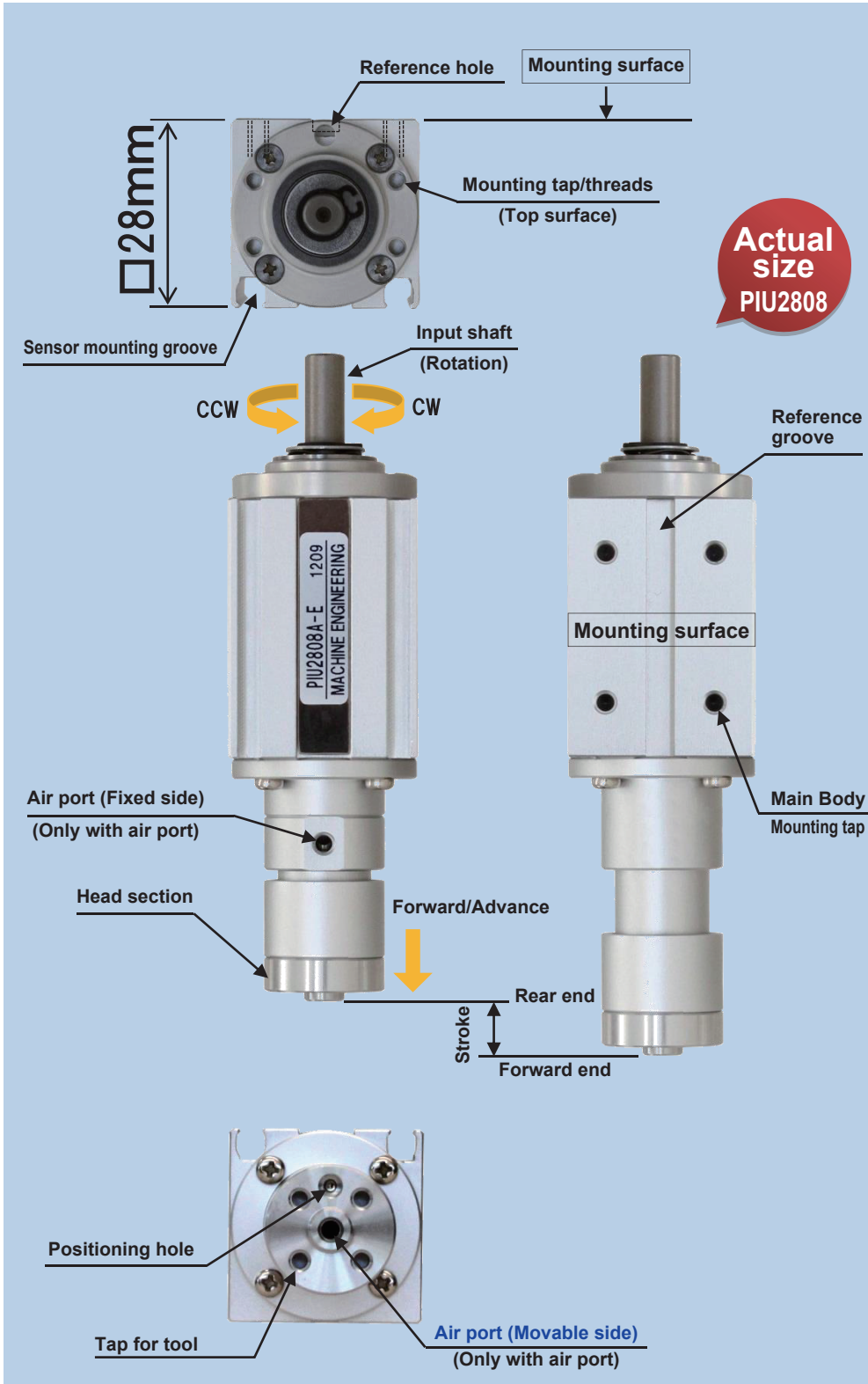

## External Input Type

This model requires the customer to prepare the drive unit.



## With Motor & Home Sensor



For the external-input type, the motor is mounted separately.

## Direct Motor Type

The motor and home sensor are integrated compactly as one unit. This helps reduce required installation space.





# Model Selection

## Series Variation

Model number	Body size (mm)	Standard stroke (mm)	Shaft Specification	Operation Specification	Operation Confirmation Sensor	Motor · Home Sensor
PIU28	□28	4 8 12 16 20 30 50	With Air Port Ball Bushing	Shockless 2-Position Free Stroke	Non-contact 2-wire Non-contact 3-wire	αSTEP AZ · AR 2-Phase Stepping Special Specification (External Input only)
PIU42	□42		Ball Spline	Forward End Position Adjustment		
PIU50	□50		Ball Spline	Above operating specifications + Free-Stroke, Reverse Home Specification Forward End Position Adjustment Reverse Home Specification		

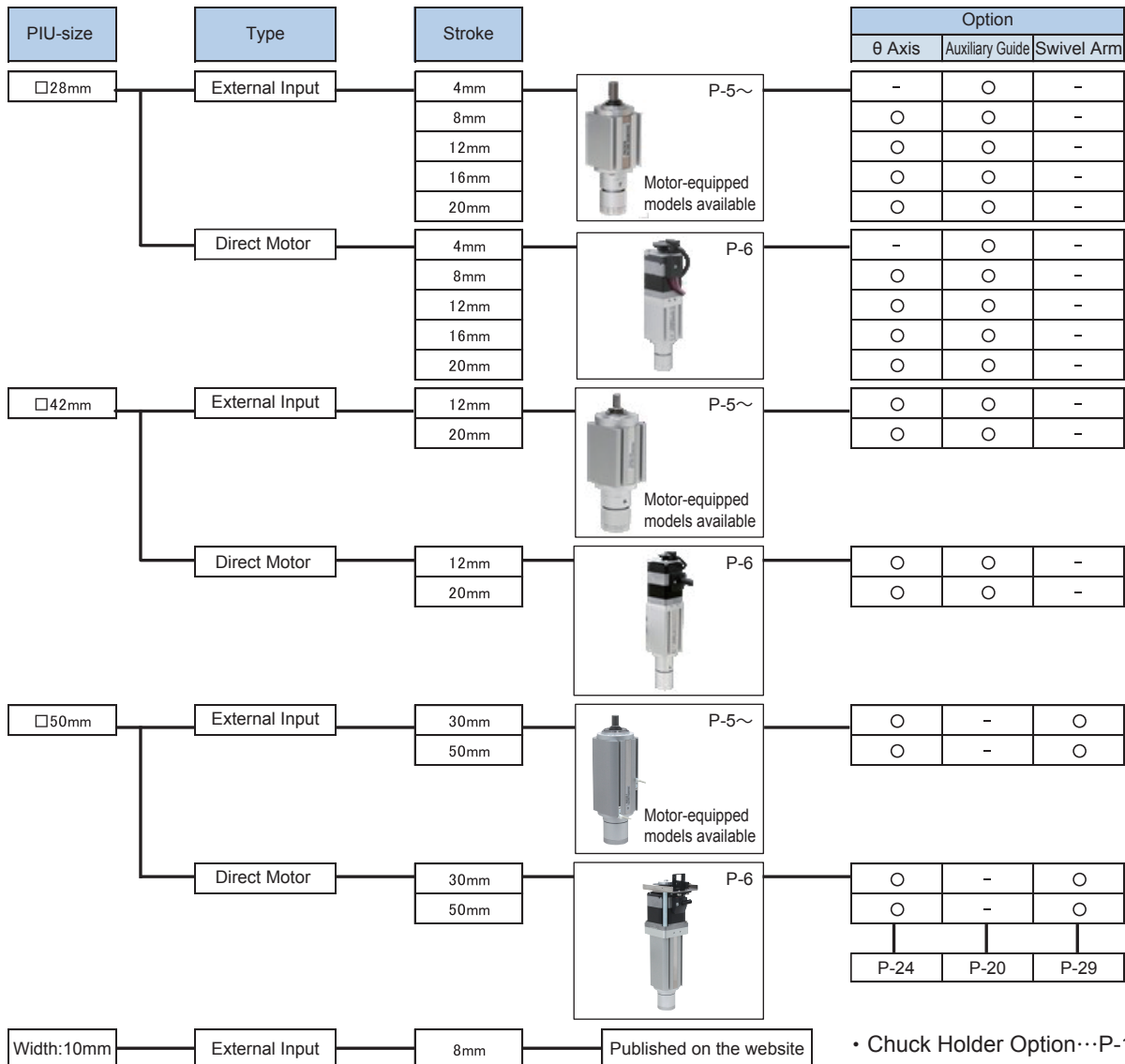

\* Please check and select after confirming the specifications for each product.

- Chuck Holder Option...P-19
- Motor Bracket Option (for External Input)...P-22

# Model Selection

## Option

### θ Axis

Mount a θ-axis to the Pick-up Unit. Since the drive section does not move up and down, smooth rotation work is achieved. With a built-in air passage, continuous rotation is possible without swinging tubes around.

\* For details, see P-24 onward.



### Swivel Arm · Rotary Head

Mount it to a □50 θ-axis to perform oscillating transfer.

\* For details, see P-29 onward.

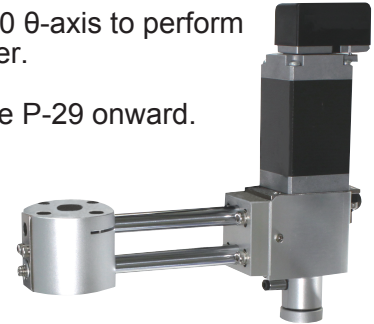

### Auxiliary Guide

For high-precision transfer where a moment load is applied in the rotational direction. The mounting orientation can be freely changed in 90° increments.

\* For details, see P-20 onward.



### Chuck Holder

Optional air-chuck mounting parts are available. Chuck model: X9608B-04

\* For details, see P-19 onward.



### Motor Bracket

For external-input type. A bracket for mounting various motors.

\* For details, see P-22 onward.



#### X-Y ROBO/Robot

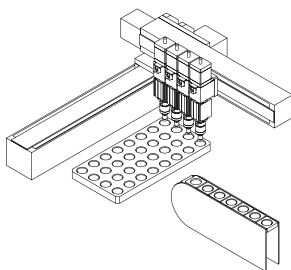

Workpieces can be taken out from and stored into pallets quickly and accurately.

#### Probe continuity inspection

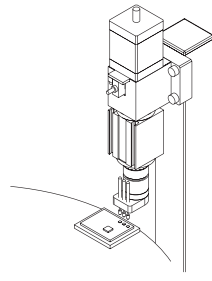

Even at high speed, the probe touches the board softly, enabling stable inspection.

#### Pick & Place work/operation · inspection process

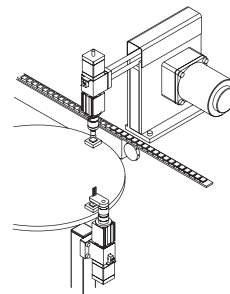

When used as the Z-axis for pick-and-place, it achieves high speed not attainable with air cylinders and realizes shockless transfer. If installed on the lower side in vertical motion of an inspection process, it allows better access from above.

#### Image inspection · Work pusher

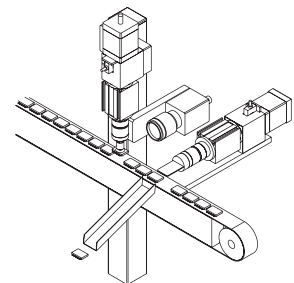

Image inspection at the pickup position. Even at high speed, soft stopping stabilizes inspection. Even at high speed, there is no workpiece pressure, so it can be used as a drive source for various units.



## Shaft Specification

# A

## With Air Port

Safe with fixed piping

With the air-port type, only the head moves, so you don't swing the air tubing—reducing risk of detachment or damage.

Slide Guide

# B

## Ball Bushing

High shaft rigidity

The ball-bush type is useful when eccentric loads are applied or for overhung applications.

Ball Bushing Guide

# S

## Ball Spline

Zero runout in the rotational direction

A compact ball spline suppresses runout in the rotational direction. It is effective for high-precision positioning.

Ball Spline Guide

Shaft Specification	Symbol	Example Application	Air tube stability	Shaft Rigidity/Stiffness
With Air Port	A		○ Built-in air piping path	△ • Used nearly on the shaft centerline
Ball Bushing	B		— No built-in air piping path	○ • Work protrudes from the head
Ball Spline	S			◎ • “S” indicates zero runout in the rotational direction

\*For the ball-bush type, an auxiliary guide option is available to further increase rigidity.

## Operation Specification (Cam Pattern)

# E

## Shockless 2-Position

Emphasis on high speed and shockless operation. Features simple control with one-direction rotation.

For image inspection that picks up workpieces, and for high-speed transfer when mounted on robots, it is ideal.

# F

## Free Stroke

Emphasis on stroke flexibility. With a wide constant-speed feed region, this is a highly versatile reciprocating-control type.

Even if heights differ, with the F specification reliable transfer is possible.

# G

## Front End Position Adjustment

Low impact & fine stroke adjustment are combined in this reciprocating-control type.

When transferring thin micro workpieces, it is ideal when fine adjustment of the front-end position is required.

Operation Specification	Code	Drive/Actuation		Operating Characteristics			Possible Pressing Range	Remarks
		Continuous Rotation	Forward/Reverse Rotation	Soft Touch Property	Stroke Flexibility	Stroke Fine Adjustment		
Shockless 2-Position (Continuous)	E	○	○	◎	×	×	1mm before the forward end	
Shockless 2-Position (Forward/Reverse)	E	×	○	◎	×	×	1mm before the forward end	Applicable to □28 with 16 and 20 mm strokes
Free Stroke	F	×	○	△	◎	○	Constant Speed Section	
Forward End Position Adjustment	G	×	○	○	△	◎	Constant Speed Section	

\*PIU□50 has reverse home-position specifications for F and G. Details: P-9

# External Input Type



- Since this is an external-input method, the drive source can be selected by the customer to suit the equipment.
- The E-cam operates with a brushless motor in continuous rotation, achieving a cycle time as fast as 0.03 seconds.
- Motor & sensor-equipped models are available.
- Motors can be selected from Oriental Motor Co., Ltd.'s αSTEP "AZ" or "AR" (DC power supply type). They are mounted separately from the Pick-up Unit, allowing maintenance individually.
- The operation sensor comes with a robot cable. Its built-in protection circuitry prevents switch damage caused by reverse wiring.
- With the ball spline guide, zero runout in the rotational direction enables more accurate operation.

### ■ Variation

Model No.		Basic stroke (mm)							
Air Port	Ball Guide	Ball Spline	4	8	12	16	20	30	50
PIU2804A	PIU2804B	-	●						
PIU2808A	PIU2808B	PIU2808S		●					
PIU2812A	PIU2812B	PIU2812S			●				
-	PIU2816B	PIU2816S				●			
-	PIU2820B	PIU2820S					●		
PIU4212A	PIU4212B	PIU4212S			●				
PIU4220A	PIU4220B	PIU4220S					●		
-	-	PIU5030S						●	
-	-	PIU5050S							●

### How to read the product code

**PIU2808A-E-SS-ZE235A-MSOZ24AK**

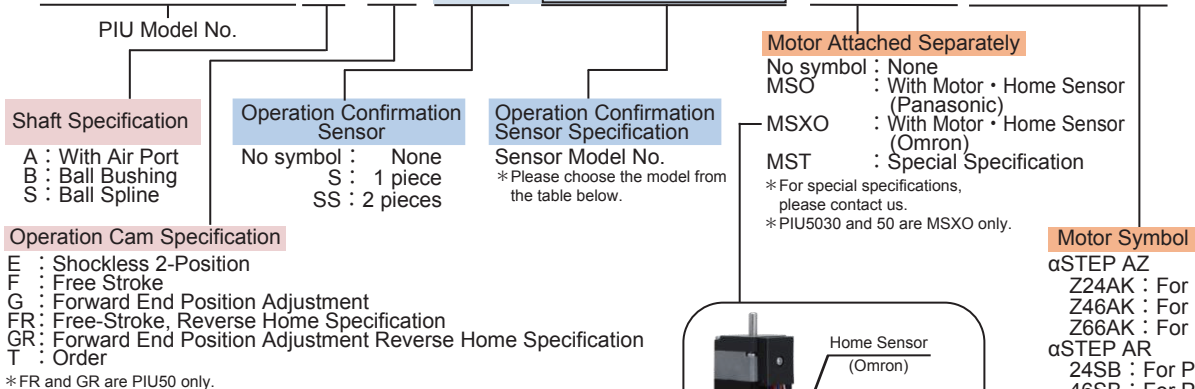

### ■ Sensor Specification

Wiring Method	Cable Exit Direction	Cable Length	
		1m	3m
2-wire type	Right Angle Direction	ZE235A	ZE235B
	Axial Direction	ZE135A	ZE135B
3-wire type	Right Angle Direction	ZE255A	ZE255B
	Axial Direction	ZE155A	ZE155B

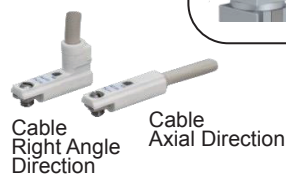

\* For sensors for PNP specifications, please contact us.



# Direct Motor Type

- A compact model with the motor and home sensor directly connected to the Pick-up Unit.
- Equipped with the highly reliable αSTEP “AR” motor that monitors and corrects position and speed.
- Compared with the □28 external-input type, overall length is reduced by 24 mm and weight is reduced by approximately 50 g.



Body size □28 (PIU28): ARM24SBK  
 Body size □42 (PIU42): ARM46SBK  
 Body size □50 (PIU50): ARM66SBK  
 \*αSTEP is by Oriental Motor Co., Ltd.

With αSTEP Motor (PIU28)

## Variation

Model No.		Basic stroke (mm)							
Air Port	Ball Guide	Ball Spline	4	8	12	16	20	30	50
PIU2804□24A	PIU2804□24B	-	●						
PIU2808□24A	PIU2808□24B	PIU2808□24S	●						
PIU2812□24A	PIU2812□24B	PIU2812□24S		●					
-	PIU2816□24B	PIU2816□24S			●				
-	PIU2820□24B	PIU2820□24S				●			
PIU4212□46A	PIU4212□46B	PIU4212□46S		●					
PIU4220□46A	PIU4220□46B	PIU4220□46S					●		
-	-	PIU5030□66S						●	
-	-	PIU5050□66S							●

\*In the actual model number, “DM” or “DMX” is inserted into □.



PIU2808DM24S

PIU4220DM46A

PIU5030DM66S

## How to read the product code

PIU2808DM24SC-G-SS-ZE235A

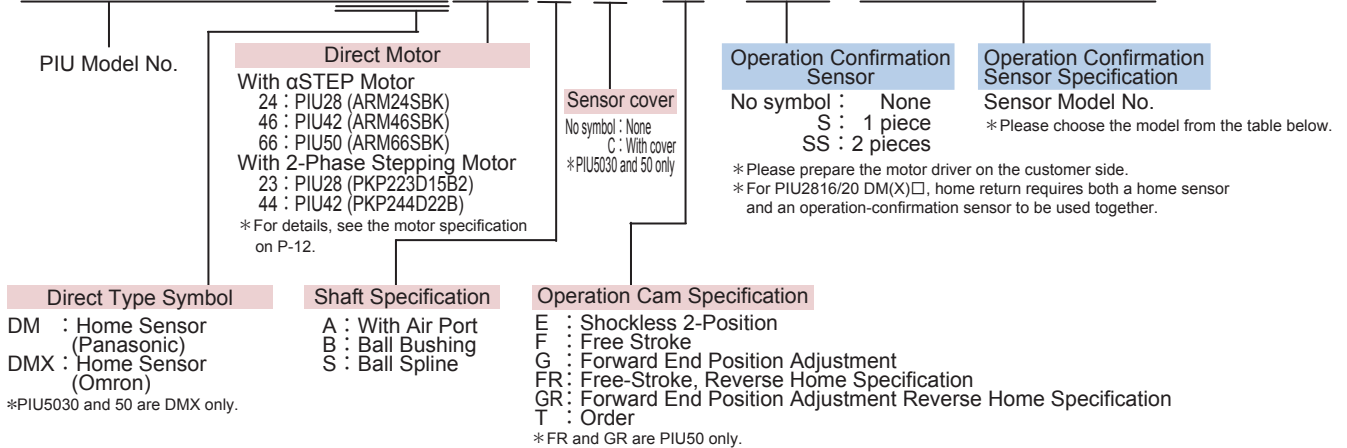

## Sensor Specification

Wiring Method	Cable Exit Direction	Cable Length	
		1m	3m
2-wire type	Right Angle Direction	ZE235A	ZE235B
	Axial Direction	ZE135A	ZE135B
3-wire type	Right Angle Direction	ZE255A	ZE255B
	Axial Direction	ZE155A	ZE155B

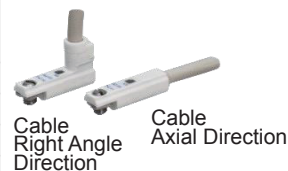

\* For sensors for PNP specifications, please contact us.



# Basic Specifications (External-input and direct-motor types)

## Basic Specifications (Common to external-input and direct-motor types)

### Shaft Specification A (With Air Port), B (Ball Bushing)

Model No. (External-input) A	PIU2804A	PIU2808A	PIU2812A	-	-	PIU4212A	PIU4220A
Model No. (Direct-motor) A	PIU2804DM(X)24A	PIU2808DM(X)24A	PIU2812DM(X)24A	-	-	PIU4212DM(X)46A	PIU4220DM(X)46A
Model No. (External-input) B	PIU2804B	PIU2808B	PIU2812B	PIU2816B	PIU2820B	PIU4212B	PIU4220B
Model No. (Direct-motor) B	PIU2804DM(X)24B	PIU2808DM(X)24B	PIU2812DM(X)24B	PIU2816DM(X)24B	PIU2820DM(X)24B	PIU4212DM(X)46B	PIU4220DM(X)46B
Operation Method	Linear/Direct Acting Cam						
Stroke (E)	4mm	8mm	12mm	16mm	20mm	12mm	20mm
Stroke (F · G)	4.5mm	8.5mm	12.5mm	16.5mm	20.5mm	12.5mm	20.5mm
Positioning Accuracy (Effective Value)	Within $\pm 0.01$ mm / $\pm 0.03^\circ$ ( $\theta$ )						
Clearance / Motion Direction / $\theta$ (Angular play)	0.02mm / $0.7^\circ$					0.03mm / $0.7^\circ$	
Ambient Temperature	10~40°C						
Lubrication	No Lubrication						

### Shaft Specification S (Ball Spline)

Model No. (External-input) S	PIU2808S	PIU2812S	PIU2816S	PIU2820S	PIU4212S	PIU4220S	PIU5030S	PIU5050S
Model No. (Direct-motor) S	PIU2808DM(X)24S	PIU2812DM(X)24S	PIU2816DM(X)24S	PIU2820DM(X)24S	PIU4212DM(X)46S	PIU4220DM(X)46S	PIU5030DM(X)66S	PIU5050DM(X)66S
Operation Method	Linear/Direct Acting Cam							
Stroke (E)	8mm	12mm	16mm	20mm	12mm	20mm	30mm	50mm
Stroke (F · G)	8.5mm	12.5mm	16.5mm	20.5mm	12.5mm	20.5mm	30.5mm	50.5mm
Positioning Accuracy (Effective Value)	$\pm 0.01$ mm							
Clearance / Motion Direction / $\theta$ (Angular play)	0.02mm				0.03mm		0.02mm	
Ambient Temperature	10~40°C							
Lubrication	No Lubrication							

\* For PIU5030S and PIU5050S, the stroke of FR and GR is the same as the stroke of F and G.

## Product mass

### External-Input Type

Model No.		PIU2804	PIU2808	PIU2812	PIU2816	PIU2820	PIU4212	PIU4220	PIU5030	PIU5050
External-input	PIU□A	90	110	127	-	-	370	463	-	-
	PIU□B	97	118	137	160	180	425	518	-	-
	PIU□S								890	1130
With Motor	PIU□A	282/322	302/342	320/360	-	-	793/933	886/1026	-	-
	PIU□B	299/329	310/350	330/370	338/378	358/398	848/988	941/1081	-	-
	PIU□S								2050	2290

\* For external-input types, motor-equipped mass values are shown with 2-phase stepping /  $\alpha$ STEP (AZ, AR). PIU5030 and 5050 are  $\alpha$ STEP (AZ, AR) only.

### Direct Motor Type PIU28

Model No.		PIU2804	PIU2808	PIU2812	PIU2816	PIU2820
$\alpha$ STEP	PIU28□DM(X)24A	249	271	285	-	-
	PIU28□DM(X)24B	257	279	295	312	341
	PIU28□DM(X)24S					
2-Phase	PIU28□DM(X)23A	222	224	258	-	-
	PIU28□DM(X)23B	230	252	268	294	314
	PIU28□DM(X)23S					

### Direct Motor Type PIU42

モデルNo.		PIU4212	PIU4220
$\alpha$ STEP	PIU42□DM(X)46A	800	890
	PIU42□DM(X)46B	854	945
	PIU42□DM(X)46S		
2-Phase	PIU42□DM(X)44A	692	782
	PIU42□DM(X)44B	746	837
	PIU42□DM(X)44S		

### Direct Motor Type PIU50

Model No.		PIU5030	PIU5050
$\alpha$ STEP	PIU50□DM(X)66S	1900	2140



## Operation timing diagram

### E Shockless 2-Position (Continuous)

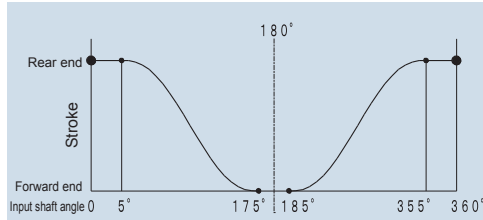

Basic Product Code	2804	2808	2812	4212	4220	5030
Stroke(mm)	4	8	12	12	20	30
Cam Curve/Profile	Modified Sine					
Input Shaft Rotation Direction	Free					

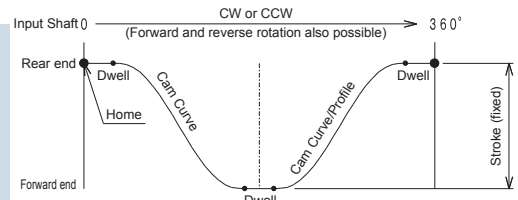

- Rotating the motor repeats forward movement → rear end.
- The input shaft can be controlled with constant-speed continuous rotation or trapezoidal control.
- It can stop in the dwell section.
- Supports 180° forward/reverse rotation
- In each 10° dwell zone at the travel ends, the head does not move (drop prevention).

### E Shockless 2-Position (Forward/Reverse)

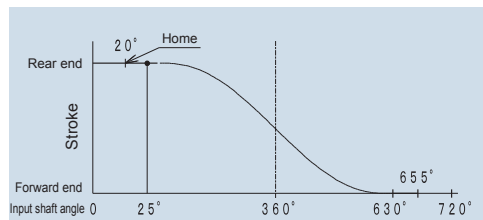

Basic Product Code	2816	2820
Stroke(mm)	16	20
Cam Curve/Profile	Modified Sine	
Input Shaft Rotation Direction	Forward during CCW	

\* Please contact us for details on PIU5050.

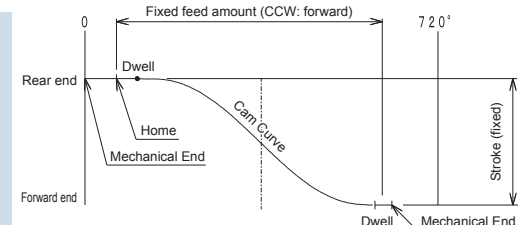

- Rotating from the home position (CCW) advances forward.
- The input shaft can be trapezoid-controlled.
- It can stop in the dwell section.
- In the dwell zones at the travel ends, the head does not move (drop prevention).

### F Free Stroke

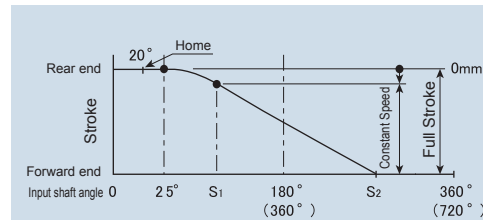

Basic Product Code	2804	2808	2812	2816	2820	4212	4220	5030	5050
Full Stroke (mm)	4.5	8.5	12.5	16.5	20.5	12.5	20.5	30.5	50.5
Constant-speed range (mm)	1~4.5	2~8.5	3~12.5	4~16.5	5~20.5	3~12.5	5~20.5	7.5~30.5	12~50.5
Constant-speed feed amount (mm/pulse)	0.032	0.064	0.096	0.064	0.08	0.096	0.16	0.21	0.20
Constant-speed start angle (S1)	129°	125°	124°	220°	220°	124°	122°	136°	214°
Constant-speed end angle (S2)	323°	306°	301°	571°	568°	301°	296°	333°	560°
Input shaft rotation direction	Forward during CCW								

\* Parentheses ( ) indicate PIU2816,PIU2820,PIU5050.

1.8/pulse

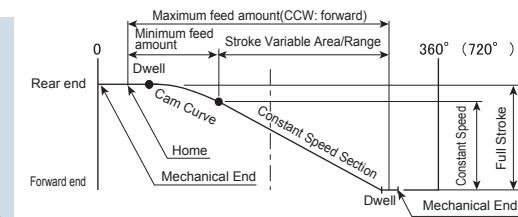

- The input shaft can be trapezoid-controlled.
- Near the rear end, the cam curve enables smooth start/stop.
- About 3/4 from the forward end is the constant-speed region.
- Use the forward position within the constant-speed region.
- In the rear-end dwell region, the head does not move (drop prevention).
- A 5° forward-end dwell is provided, but it is normally not used.
- Do not use it by hitting the mechanical end.

### G Forward End Position Adjustment

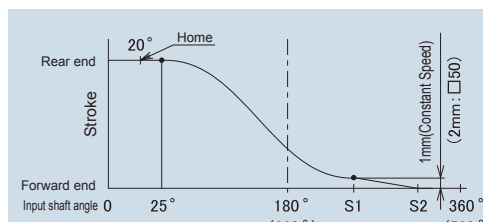

Basic Product Code	2804	2808	2812	2816	2820	4212	4220	5030	5050
Full Stroke (mm)	4.5	8.5	12.5	16.5	20.5	12.5	20.5	30.5	50.5
Constant-speed range (mm)	From the forward end to 1 mm before it								From the forward end to 2 mm before it
Constant-speed feed amount (mm/pulse)	0.025mm								
Constant-speed start angle (S1)	219°	219°	219°	500°	500°	219°	219°	244°	474°
Constant-speed end angle (S2)	291°	291°	291°	571°	571°	291°	291°	316°	546°
Input shaft rotation direction	Forward during CCW								

\* Parentheses ( ) indicate PIU2816,PIU2820,PIU5050.

1.8/pulse

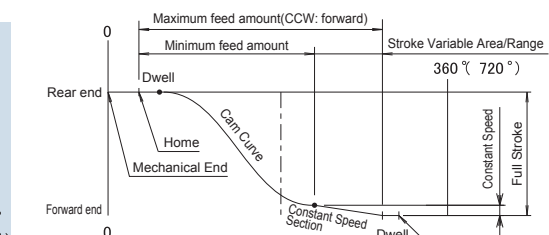

- The input shaft can be trapezoid-controlled.
- Until entering the constant-speed region from the rear end, the cam curve provides smoother movement.
- In the rear-end dwell region, the head does not move (drop prevention).
- A 5° forward-end dwell is provided, but it is normally not used.
- Do not use it by hitting the mechanical end.

# Basic Specifications

## FR Free-Stroke, Reverse Home Specification

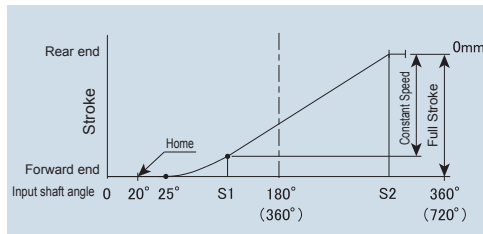

Basic Product Code	5030	5050
Full Stroke (mm)	30.5	50.5
Constant-speed range (mm)	7.5~30.5	12~50.5
Constant-speed feed amount (mm/pulse)	0.21	0.20
Constant-speed start angle (S1)	136°	214°
Constant-speed end angle (S2)	333°	560°
Input shaft rotation direction	Forward during CCW	

\* Parentheses ( ) indicate PIU5050. 1.8/pulse

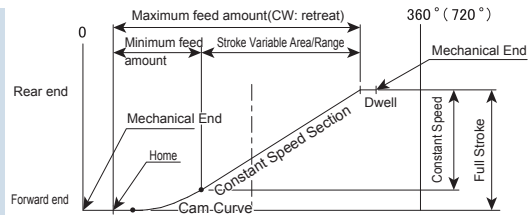

- The input shaft can be trapezoid-controlled.
- Near the forward end, the cam curve enables smooth start/stop.
- About 3/4 from the rear end is the constant-speed region.
- Use the retreat position within the constant-speed region.
- In the forward-end dwell region, the head does not move (drop prevention).
- A 5° rear-end dwell is provided, but it is normally not used.
- Do not use it by hitting the mechanical end.

## GR Forward End Position Adjustment Reverse Home Specification

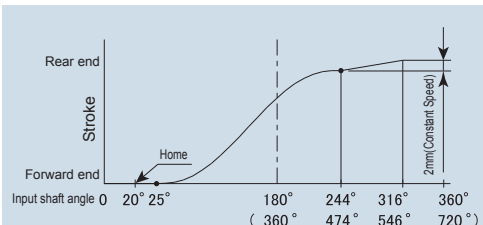

Basic Product Code	5030	5050
Full Stroke (mm)	30.5	50.5
Constant-speed range (mm)	From the retreat end to 2 mm before it	
Constant-speed feed amount (mm/pulse)	0.05mm	
Input shaft rotation direction	Forward during CCW	

\* Parentheses ( ) indicate PIU5050. 1.8/pulse

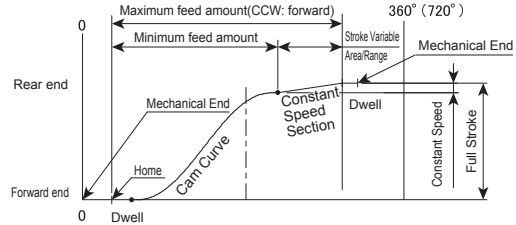

- The input shaft can be trapezoid-controlled.
- Until entering the constant-speed region from the forward end, the cam curve provides smoother movement.
- In the forward-end dwell region, the head does not move (drop prevention).
- A 5° rear-end dwell is provided, but it is normally not used.
- Do not use it by hitting the mechanical end.

## ■ Cycle time and allowable payload (Common to shaft specifications A, B, and C)

### PIU28

**E** (External Input)

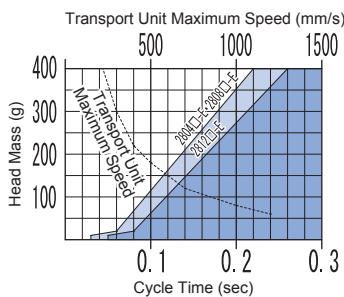

**E** (With a STEP)

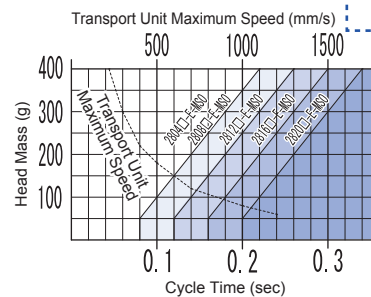

**F** (External Input · With a STEP)

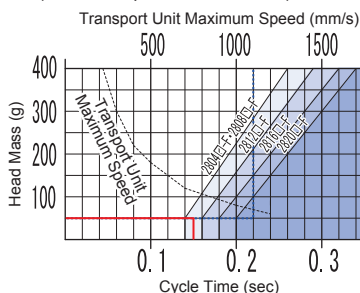

**G** (External Input · With a STEP)

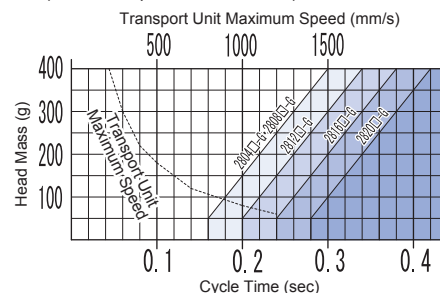

### Selection Method

1. The intersection of cycle time and head mass must be in the operating range (to the right of the line).  
Example: 50 g at 0.15 s with PIU2808F (red line)... usable
2. The intersection of the transport unit maximum speed and head mass must be in the operating range (to the left of the line).  
Example: 50 g at 1100 mm/s (blue line)... usable

- Note 1. The external input for 'E' is for continuous use with brushless motors, etc.
2. For 'E' with a motor, models 2804, 2808, and 2812 are for 360° continuous rotation.
  3. For 'E' with a motor, models 2816 and 2820 are for forward/reverse rotation only (continuous rotation is not possible). Forward-end stop time is 20 ms.
  4. Set the acceleration/deceleration time to 30ms or more for each.

5. The forward-end stop time for F and G is 20 ms.
6. Set the acceleration/deceleration time to 30ms or more for each.

\*For E/F/G with 2-phase stepping motor, please contact us.



## PIU42

### E (External Input)

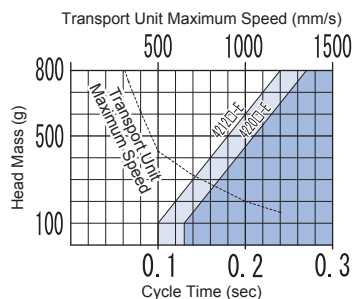

### E (With $\alpha$ STEP)

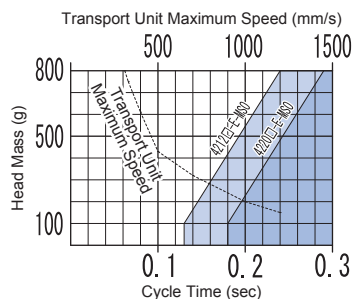

### F (External Input · With $\alpha$ STEP)

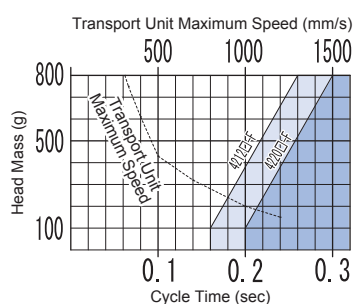

### G (External Input · With $\alpha$ STEP)

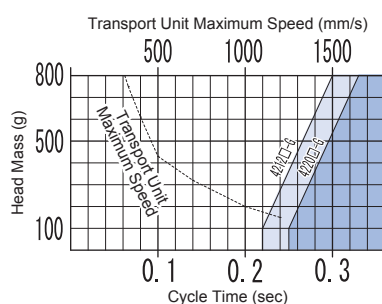

- Note 1. The external input for 'E' is for continuous use with brushless motors, etc.
- 2. Motor-equipped E is for 360° continuous rotation.
- 3. Set the acceleration/deceleration time to 30ms or more for each.

- 4. The forward-end stop time for F and G is 20 ms.
- 5. Set the acceleration/deceleration time to 30ms or more for each.

\*For E/F/G with 2-phase stepping motor, please contact us.

## PIU50

### E (External Input · With $\alpha$ STEP)

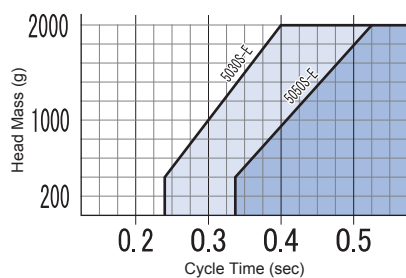

### F,FR (External Input · With $\alpha$ STEP)

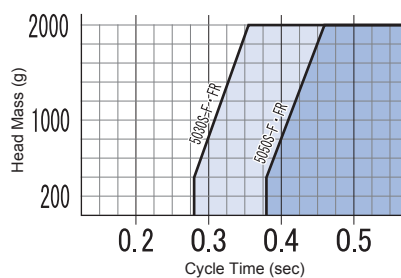

- Note 1. PIU5030E is for 360° continuous rotation.
- PIU5050E is forward/reverse rotation.

### G,GR (External Input · With $\alpha$ STEP)

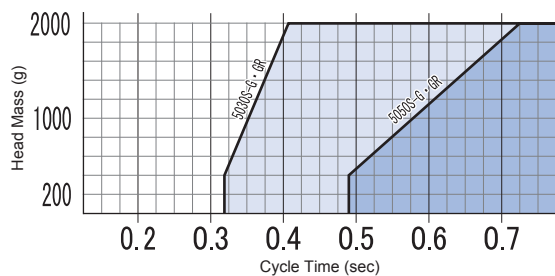

- 3. The forward-end stop time for F and G is 20 ms.
- 4. Set the acceleration/deceleration time to 30ms or more for each.

# Basic Specifications

The allowable pressing load has been updated. Suitable for a wide range of applications.

## Load Capacity – Overhang

\*In the graphs below, PIU28□B and PIU42□B refer to ball-bush and ball-spline cases.  
\*For PIU□50 and 2-phase stepping motor, please contact us.

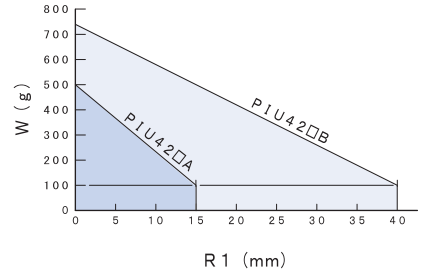
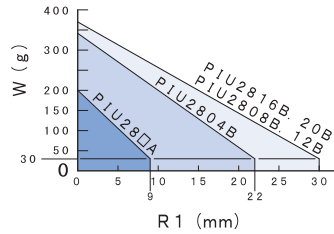
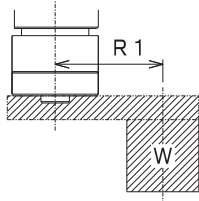

## Pressing Load

PIU Allowable Pressing Load	Shaft Specification		
	With Air Port (A)	Ball Bushing (B)	Ball Spline (S)
PIU28 External Input Type	5N	15N	20N
PIU28 Direct Motor Type	5N	15N	20N
PIU42 External Input Type	15N	20N	30N
PIU42 Direct Motor Type	15N	20N	30N

\*For PIU50, please contact us.

## Pressing Load – Overhang

\*Depending on the operating specifications, the obtainable pressing load within the stroke is limited. Please confirm the operation specifications on P-4.

\*The graphs below show "Ball Spline (S) Pressing Input." (PIU2804 is ball-bush external-input)  
For all types, pressing load values are as listed above.

\*To minimize pressing impact, the Ball Spline type is recommended.

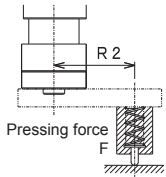

Air Port Type  
R2=0 (no overhang) Only  
PIU28□A--F: 5N  
PIU42□A--F: 15N

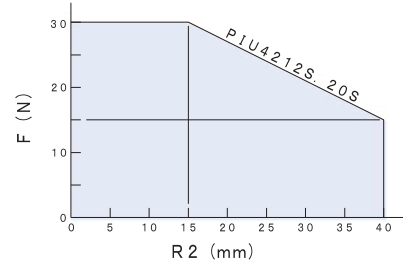
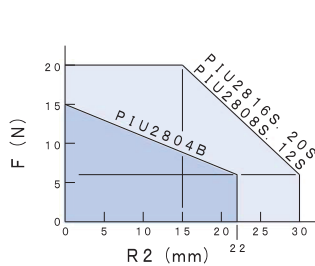

## Input Torque – Output (Generated Thrust)

Please use as a reference value.



- If motor torque exceeds permissible thrust, verify the motor specifications.
- Do not apply impact loads.

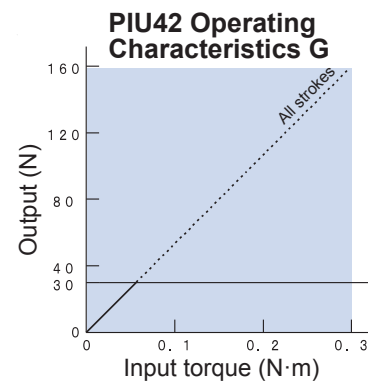
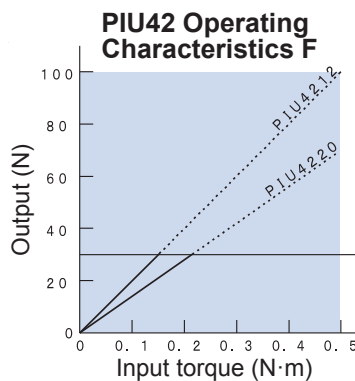
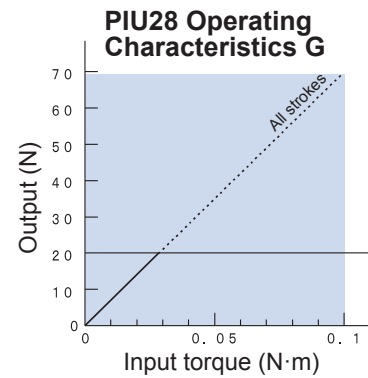
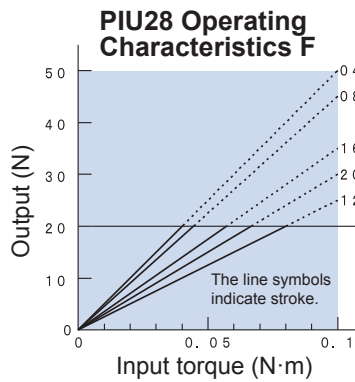



# Drive Section & Sensors (Home Position / Operation Detection)

## External Input Type with Motor – Motor Specifications

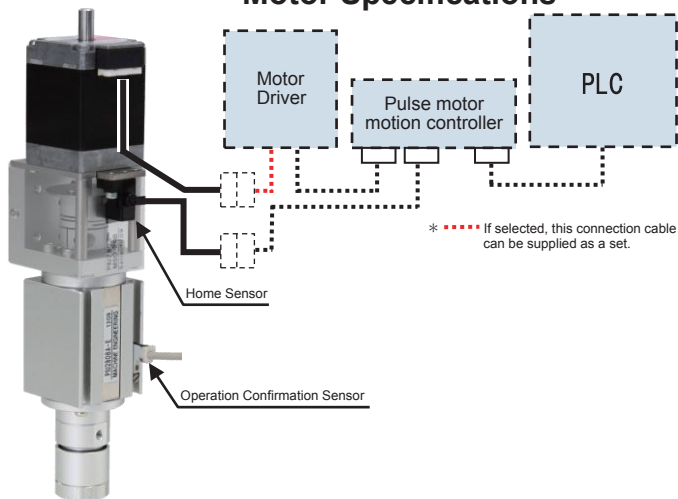

## Direct Motor Type – Motor Specifications

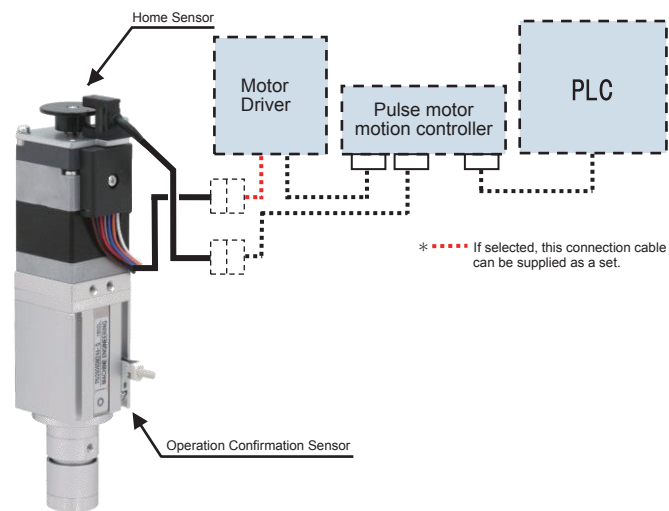

### α STEP AZ

PIU Model No.	PIU28□□	PIU42□□	PIU50□□
Motor Symbol	Z24AK	Z46AK	Z66AK
Name	αSTEP DC Power supply type		
Type	AZM24AK	AZM46AK	AZM66AK
Basic Step Angle	Set to 1000P/R 0.36°/Pulse		
Maximum Holding torque	0.095N·m	0.35N·m	1.0N·m
Recommended Driver	AZD-K		
Recommended Driver Cable (Between the motor and driver (e.g., 2m))	CC020VZ2F2	CC020VZ2F2	
Power Input	DC24V±5% 1.6A	DC24V±5% 1.72A	DC24V±5% 3.6A

Note 1. Please select the motor driver and connection cables as required.  
2. For motor details, please refer to Oriental Motor Co., Ltd. catalog.

### α STEP AR

PIU Model No.	PIU28□□	PIU42□□	PIU50□□
Motor Symbol	24SB	46SB	66SB
Name	αSTEP DC Power supply type		
Type	ARM24SBK	ARM46SBK	ARM66SBK
Basic Step Angle	Set to 1000P/R 0.36°/Pulse		
Maximum Holding torque	0.055N·m	0.3N·m	1.0N·m
Recommended Driver	ARD-K		
Recommended Driver Cable (Between the motor and driver (e.g., 2m))	CC020VA2F2		
Power Input	DC24V±10% 0.9A	DC24V±10% 1.4A	DC24V±10% 3.1A

Note 1. Please select the motor driver and connection cables as required.  
2. For motor details, please refer to Oriental Motor Co., Ltd. catalog.

### 2-Phase Stepping Motor

PIU Model No.	PIU28□□	PIU42□□
Motor Symbol	23DB	44DB
Name	2-Phase bipolar stepper Motor CVK series	
Type	PKP223D15B2	PKP244D23B
Basic Step Angle	1.8°	
Maximum Holding torque	0.095N·m	0.48N·m
Recommended Driver	CVD215-K	CVD223-K
Recommended Driver Cable	LOS01CVK2 (3 types, 0.6m each)	
Power Input	DC24V±10% 1.3A	DC24V±10% 2A

Note 1. Please select the motor driver and connection cables as required.  
2. A 0.6 m motor connection cable is included.  
PIU28:LC2B06A,PIU42:LC2B06B  
3. For motor details, please refer to Oriental Motor Co., Ltd. catalog.

### α STEP AR

PIU Model No.	PIU28□DM(X)24	PIU42□DM(X)46	PIU50□DM(X)66
Name	αSTEP DC Power supply type		
Type	ARM24SBK	ARM46SBK	ARM66SBK
Basic Step Angle	Set to 1000P/R 0.36°/Pulse		
Maximum Holding torque	0.055N·m	0.3N·m	1.0N·m
Recommended Driver	ARD-K		
Recommended Driver Cable (Between the motor and driver (e.g., 2m))	CC020VA2F2		
Power Input	DC24V±10% 0.9A	DC24V±10% 1.4A	DC24V±10% 3.1A

Note 1. Please select the motor driver and connection cables as required.  
2. For motor details, please refer to Oriental Motor Co., Ltd. catalog.

### 2-Phase Stepping Motor

PIU Model No.	PIU28□□DM(X)23	PIU42□□DM(X)44
Name	2-Phase bipolar stepper Motor CVK series	
Type	PKP223D15B2	PKP244D23B
Basic Step Angle	1.8°	
Maximum Holding torque	0.095N·m	0.3N·m
Recommended Driver	CVD215-K(CVK series)	CVD223-K(CVK series)
Recommended Driver Cable	LOS01CVK2 (3 types, 0.6m each)	
Power Input	DC24V±10% 1.3A	DC24V±10% 2A

Note 1. Please select the motor driver and connection cables as required.  
2. A 0.6 m motor connection cable is included.  
PIU28:LC2B06A,PIU42:LC2B06B  
3. For motor details, please refer to Oriental Motor Co., Ltd. catalog.

**Home Sensor Specifications – Panasonic Corp. Sensor**

Sensor Name	Photo-micro Sensor
Model	PM-R25-R
Manufacturer	Panasonic
Dog	Slit dog (Light is received at the rear dwell position.)
Power Supply Voltage	DC 5–24 V ±10% (Ripple PP ≤10%)
Current Consumption	15 mA or less
Indicator	Light reception indicator (LED)
Cable Length	1 m

**Output Operation**

Output	Lead wire color	Output Action
Output 1	Black	ON when light received

\*At the home position, the light is received (light-on state).  
 \*White lead wire is not used for this sensor.

**1. Input/output circuit diagram 2. Wiring diagram**

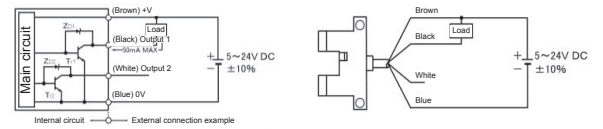

Symbol... Z<sub>01</sub>, Z<sub>02</sub>: Zener diode for absorbing surge voltage  
 T<sub>1</sub>, T<sub>2</sub>: NPN output transistor

Note 1. For PIU2816 and PIU2820, operation does not complete within one rotation of the input shaft (dog). Use the operation-confirmation sensor to confirm the home position.

**Home Sensor Specifications – OMRON Corp. Sensor**

Name	Built-in Amplifier Photo-micro Sensor (Connector Type)
Manufacturer	OMRON Corporation
Model	EE-SX673A
Power Supply Voltage	DC 5–24 V ±10% (Ripple PP ≤10%)
Current Consumption	35 mA or less
Indicator	Lights ON when blocked (red)
Included Connector	Model EE-1001

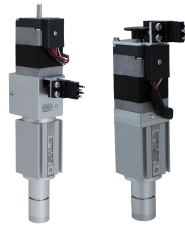

**Input/output circuit diagram**

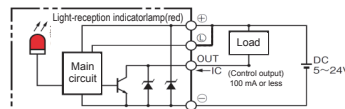

\*Short between L and +.

**Sensor shape**

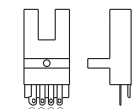

**Output Operation**

\*At the home position, the light is received (light-on state).

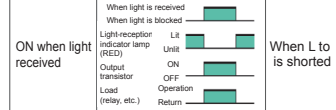

\*The indicator light is OFF at the home position.

**Wiring diagram**

Terminal arrangement

①	DC5V~24V
②	L*
③	OUTPUT
④	0V

**Operation Confirmation Sensor New Model Specifications (Robot Cable)**

Mode	ZE235 / ZE135	ZE255 / ZE155
Wiring Method	2wire	3wire
Power Supply Voltage	—	DC 4.5–28 V
Load Voltage	DC 10–28 V	DC 4.5–28 V
Load Current	2.5–20 mA (at 25°C)	40 mA max
Weight	15 g (1 m), 35 g (3 m)	
Manufacturer	KOGANEI Co., Ltd.	

**Sensor Dimensions (ZE)**

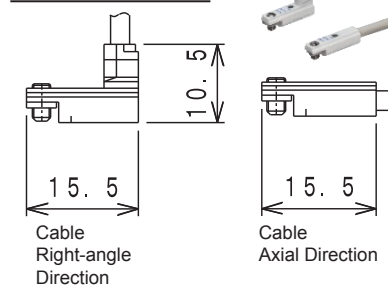

**Internal Circuit**

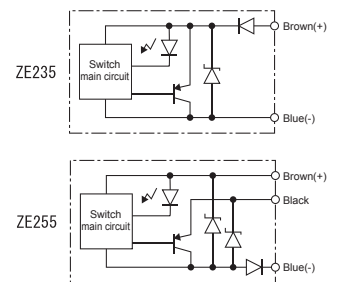

**Basic Circuit**

● 2-wire

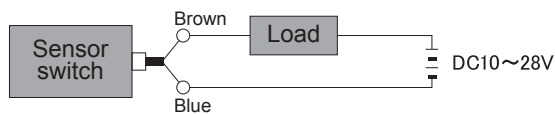

● 3-wire

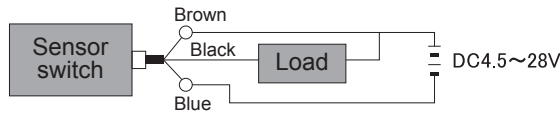

**Connection**

**2-wire type**

● Connection with a programmable controller

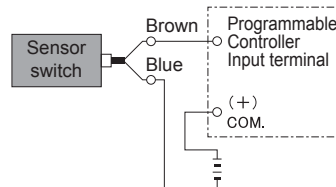

**3-wire NPN Output type**

● Connection with a programmable controller

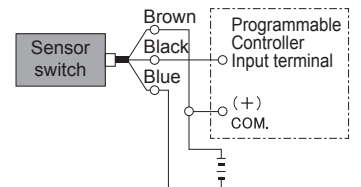

**Sensor Mounting Dimensions**

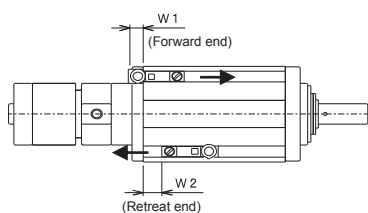

Cable Exit Direction	Sensor Model	PIU28□					PIU42□			PIU50□			
		W1	W2				W1	W2	W1	W2			
Right-angle Direction	ZE2□5	5	4	8	12	16	20	0	15	23	4	31	51
Axial Direction	ZE1□5	5	2	6	10	14	18	0	15	23	4	31	51

- Dimensions measured from end surface of PIU body (□28, 42, 50).
- Indicates approximate limit position for 'ON'.
- For safety, install with at least 1 mm offset in indicated direction.
- Ensure space so the protruding sensor part does not interfere with surroundings.
- If PIUs are placed too close together, internal magnetic forces may interfere and cause sensor malfunction. As a guideline, keep at least 10 mm separation.



# Dimension Drawings

External Input Type (PIU28, PIU42)

## Main Body

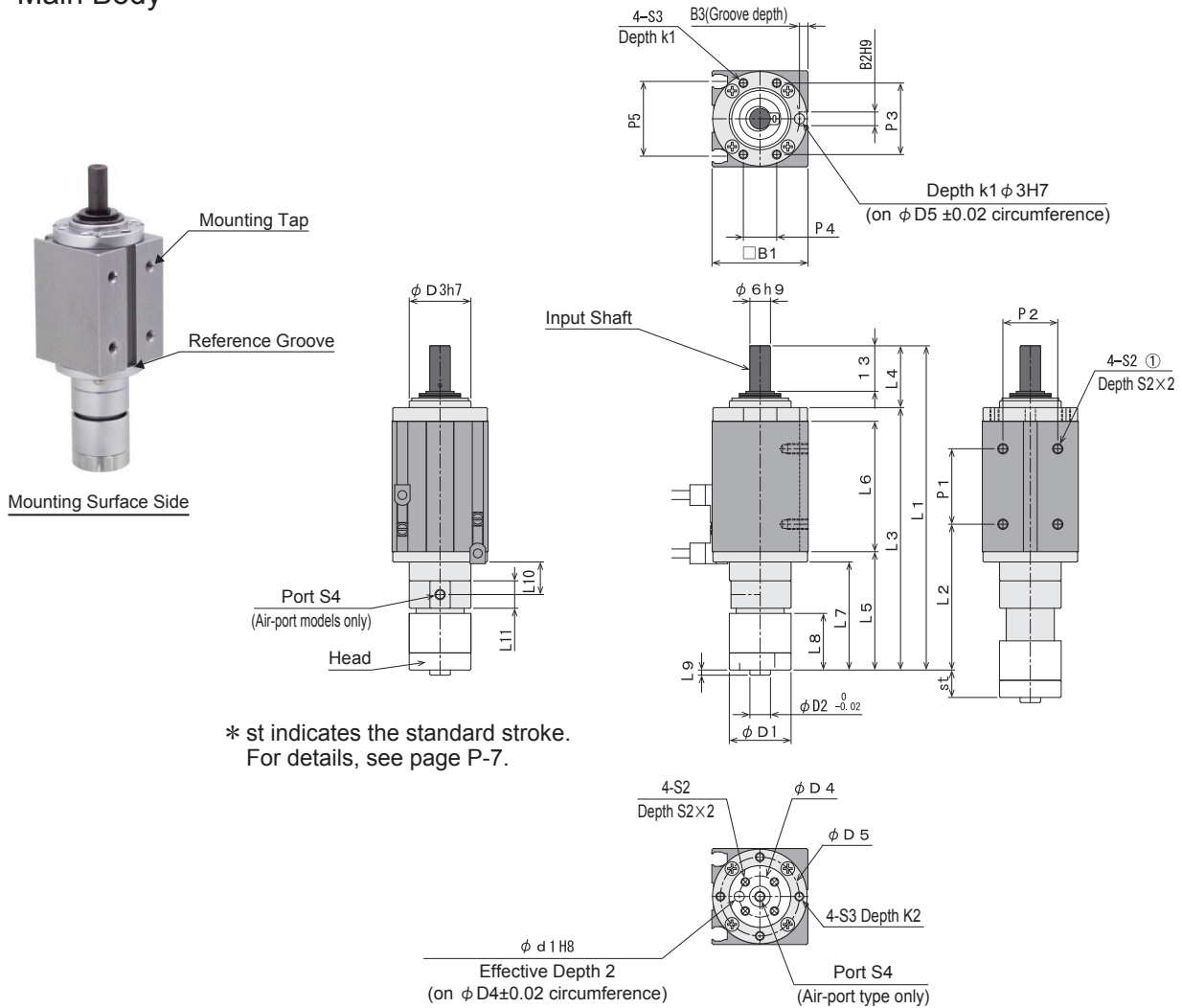

\* st indicates the standard stroke.  
For details, see page P-7.

Model No.	Stroke	Length											Pitch				
	st	L1	L2	L3	L4	L5	L6	L7	L8	L9	L10	L11	P1	P2	P3	P4	P5
PIU2804	4	78.5	34.5	60.5	18	26.5	30	23.5	12.5	1.5	5.5	8	14	16	20.9	9.7	21.8
PIU2808	8	94.5	42.5	76.5	18	34.5	38	31.5	16.5	1.5	9.5	8	22	16	20.9	9.7	21.8
PIU2812	12	110.5	50.5	92.5	18	42.5	46	39.5	20.5	1.5	13.5	8	30	16	20.9	9.7	21.8
PIU2816	16	126.5	58.5	108.5	18	50.5	54	47.5	24.5	1.5	-	-	38	16	20.9	9.7	21.8
PIU2820	20	142.5	66.5	124.5	18	58.5	62	55.5	28.5	1.5	-	-	46	16	20.9	9.7	21.8
PIU4212	12	136	57	115	21	49	58	44	22.3	2	14.2	12	42	30	32.2	15	27
PIU4220	20	168	73	147	21	65	74	60	30.3	2	22.2	12	58	30	32.2	15	27

Model No.	Width			Holes	Taps				Diameter						
	B1	B2	B3	d1	S1	S2	S3	S4	k1	k2	D1	D2	D3	D4	D5
PIU28□	28	4	2.5	3	M3	M2.5	M2.6	M3	4	3	18	6	18	12	23
PIU42□	42	6	3.5	4	M4	M3	M3	M5	8	5	28	10	28	20	35.5

# Dimension Drawings

External Input Type (PIU28, PIU42)

With Motor & Home Sensor

- α STEP AZ
- α STEP AR
- 2-Phase Stepping Motor

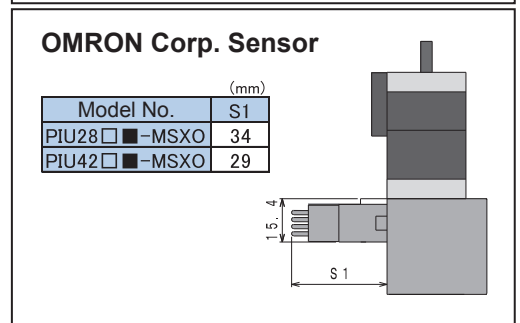
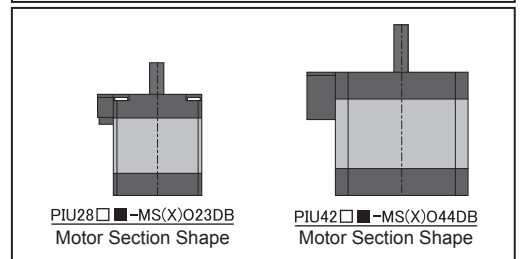
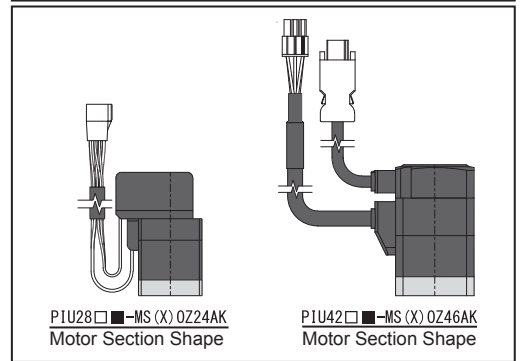
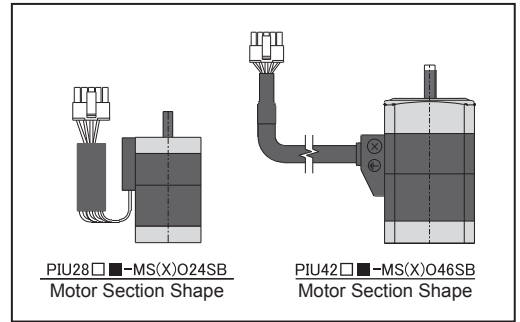
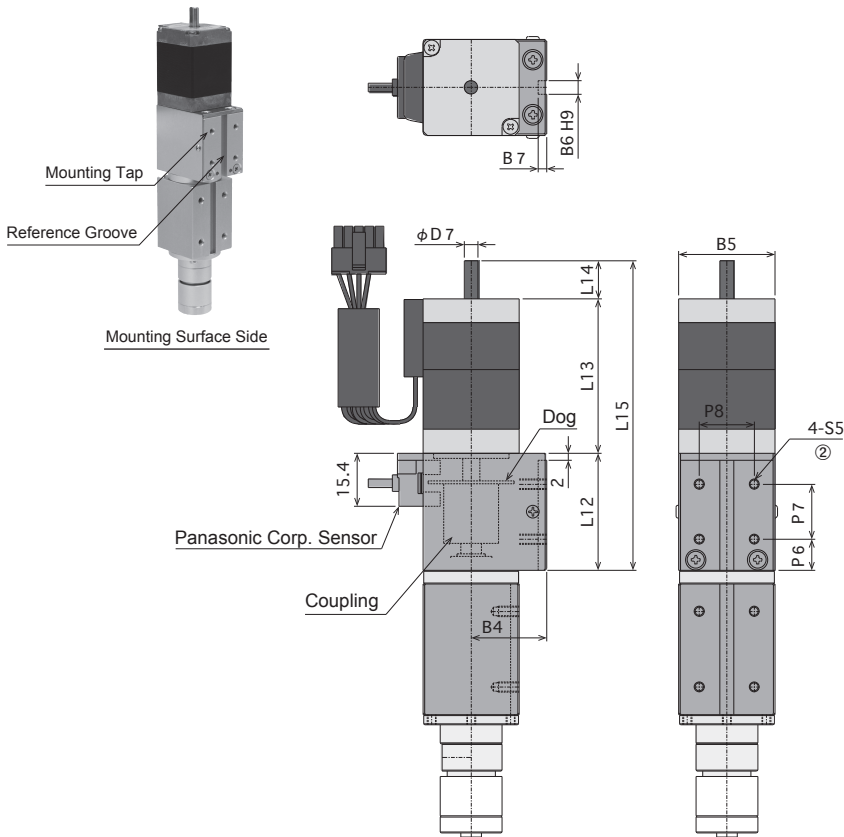

α STEP AZ

Model No.	Length				Diameter	Width				Pitch			Taps
	L12	L13	L14	L15		B4	B5	B6	B7	P6	P7	P8	
PIU28 $\square$ $\blacksquare$ -MS(X)OZ24AK	34	54.5	-	88.5	-	22	28	4	2.5	9	16	16	M3
PIU42 $\square$ $\blacksquare$ -MS(X)OZ46AK	42	70	-	112	-	31	42	6	3.5	11	20	30	M4

α STEP AR

Model No.	Length				Diameter	Width				Pitch			Taps
	L12	L13	L14	L15		B4	B5	B6	B7	P6	P7	P8	
PIU28 $\square$ $\blacksquare$ -MS(X)O24SB	34	45	11	90	4	22	28	4	2.5	9	16	16	M3
PIU42 $\square$ $\blacksquare$ -MS(X)O46SB	42	67.5	15.5	125	5	31	42	6	3.5	11	20	30	M4

2-Phase Stepping Motor

Model No.	Length				Diameter	Width				Pitch			Taps
	L12	L13	L14	L15		B4	B5	B6	B7	P6	P7	P8	
PIU28 $\square$ $\blacksquare$ -MS(X)O23DB	34	32	10	76	5	22	28	4	2.5	9	16	16	M3
PIU42 $\square$ $\blacksquare$ -MS(X)O44DB	42	39	15	96	5	31	42	6	3.5	11	20	30	M4

\* For PIU28  $\square$   $\blacksquare$ ,  $\square$  is 04, 08, 12, 16, or 20.  $\blacksquare$  is A, B, or S. (See page P-5 for details)

\* For PIU42  $\square$   $\blacksquare$ ,  $\square$  is 12 or 20.  $\blacksquare$  is A, B, or S.



## Direct Motor Type (PIU28, PIU42)

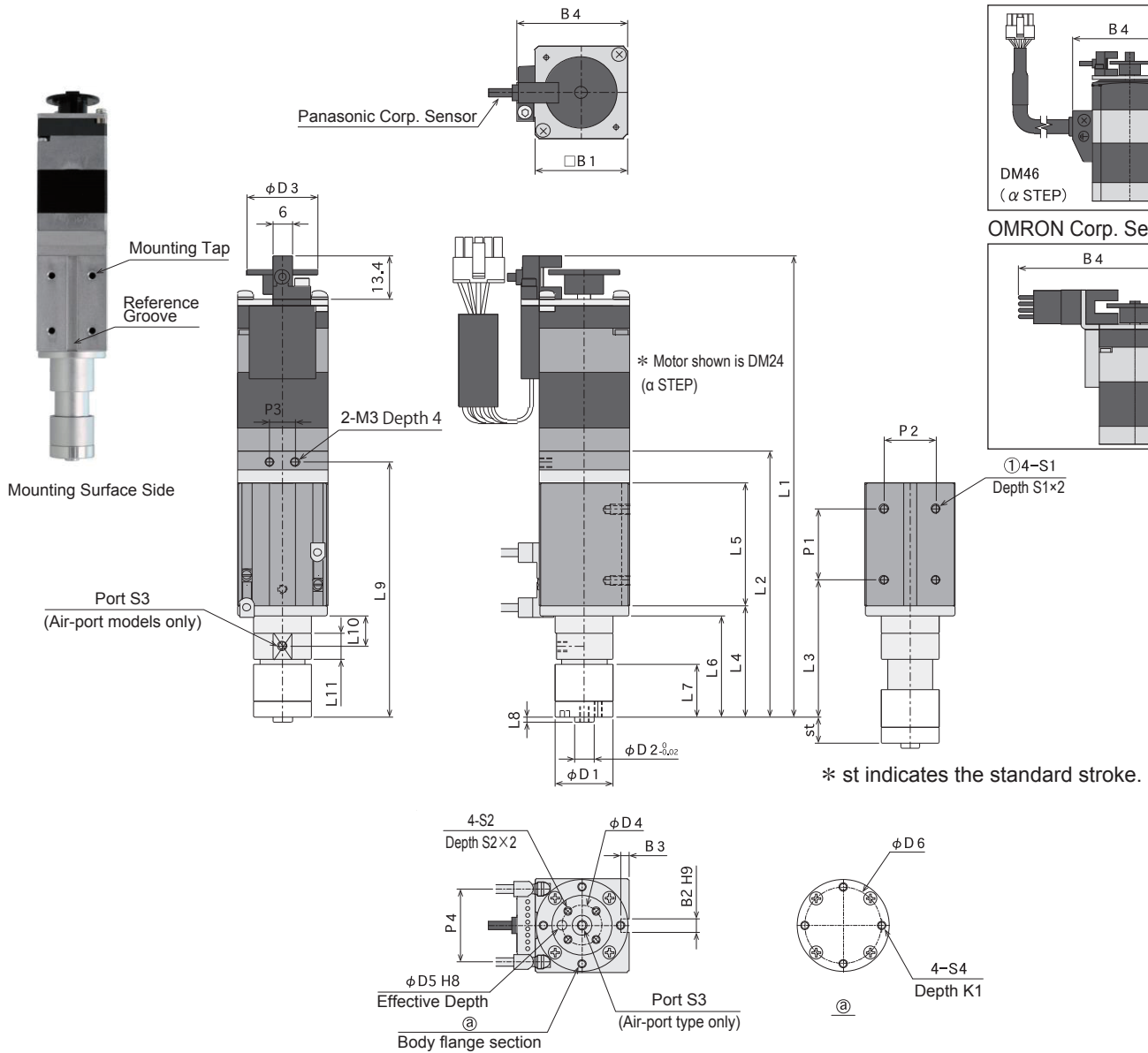

### α STEP AR Motor

Model No.	Stroke st	Length											Pitch			
		L1	L2	L3	L4	L5	L6	L7	L8	L9	L10	L11	P1	P2	P3	P4
PIU2804DM(X)24 ■	4	126.9	66.5	34.5	26.5	30	23.5	12.5	1.5	63	5.5	8	14	16	8	21.8
PIU2808DM(X)24 ■	8	142.9	82.5	42.5	34.5	38	31.5	16.5	1.5	79	9.5	8	22	16	8	21.8
PIU2812DM(X)24 ■	12	158.9	98.5	50.5	42.5	46	39.5	20.5	1.5	95	13.5	8	30	16	8	21.8
PIU2816DM(X)24 ■	16	174.9	114.5	58.5	50.5	54	47.5	24.5	1.5	111	-	-	38	16	8	21.8
PIU2820DM(X)24 ■	20	190.9	130.5	66.5	58.5	62	55.5	28.5	1.5	127	-	-	46	16	8	21.8
PIU4212DM(X)46 ■	12	200.4	117	57	49	58	44	22.3	2	114	14.2	12	42	30	15	27
PIU4220DM(X)46 ■	20	232.4	149	73	65	74	60	30.3	2	146	22.2	12	58	30	15	27

Model No.	Width				Holes D5	Taps				K1	Diameter					
	B1	B2	B3	B4		S1	S2	S3	S4		D1	D2	D3	D4	D6	
PIU28□DM24 ■	28	4	2.5	33.5	3	M3	M2.5	M3	M2.6	3	18	6	22	12	23	
PIU28□DMX24 ■				60												
PIU42□DM46 ■	42	6	3.5	53	4	M4	M3	M5	M3	5	28	10	22	20	35.5	
PIU42□DMX46 ■				67												

- is A, B, or S. (See page P-6 for details)
- \* CAD data is available.
- \* See operation confirmation sensor section on P-13.
- \* For 2-phase stepping motor models, except L1 and B4, refer to α STEP model.
- \* B4 notation for 2-phase stepping motor corresponds to DM/DMX.

### 2-Phase Motor

Model No.	Length	Width
	L1	B4
PIU2804DM(X)23 ■	113.9	33.5/60
PIU2808DM(X)23 ■	129.9	33.5/60
PIU2812DM(X)23 ■	145.9	33.5/60
PIU2816DM(X)23 ■	161.9	33.5/60
PIU2820DM(X)23 ■	177.9	33.5/60
PIU4212DM(X)44 ■	171.4	51/67
PIU4220DM(X)44 ■	203.4	51/67

# Dimension Drawings

External Input Type (PIU50)

## Main Body

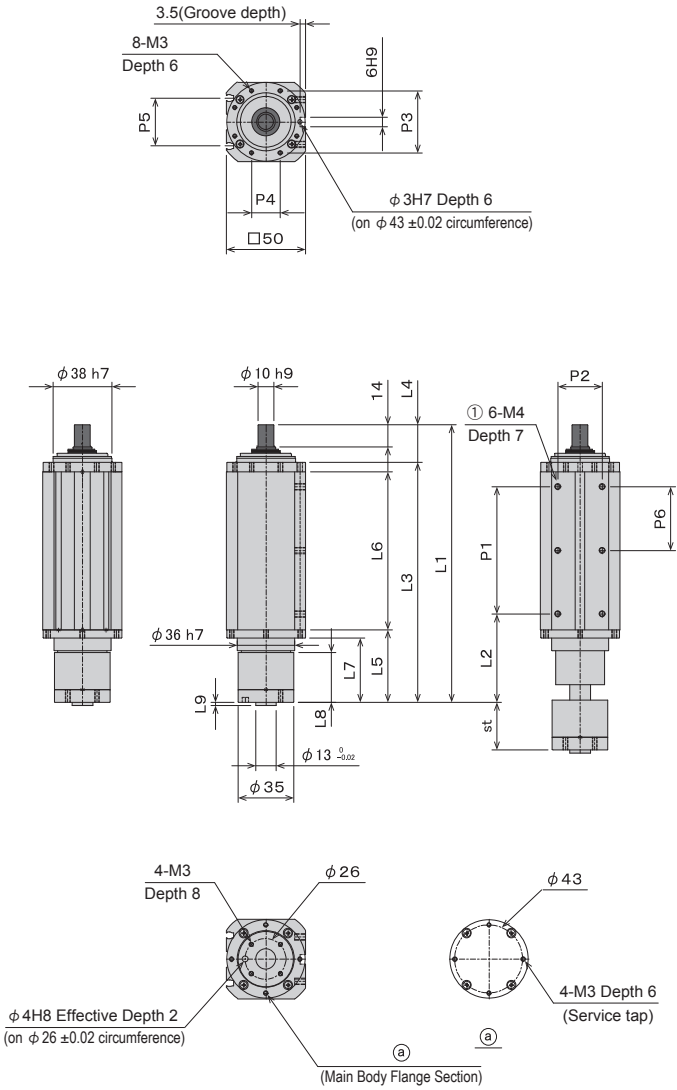

Model No.	Stroke st	Length								
		L1	L2	L3	L4	L5	L6	L7	L8	L9
PIU5030	30	174.5	55.5	151	23.5	45.5	99.5	40.5	31.3	2
PIU5050	50	313.3		191						

Model No.	Pitch					
	P1	P2	P3	P4	P5	P6
PIU5030	80					40
PIU5050	120	28	39	18	30	60

## With Motor & Home Sensor

- α STEP AZ
- α STEP AR

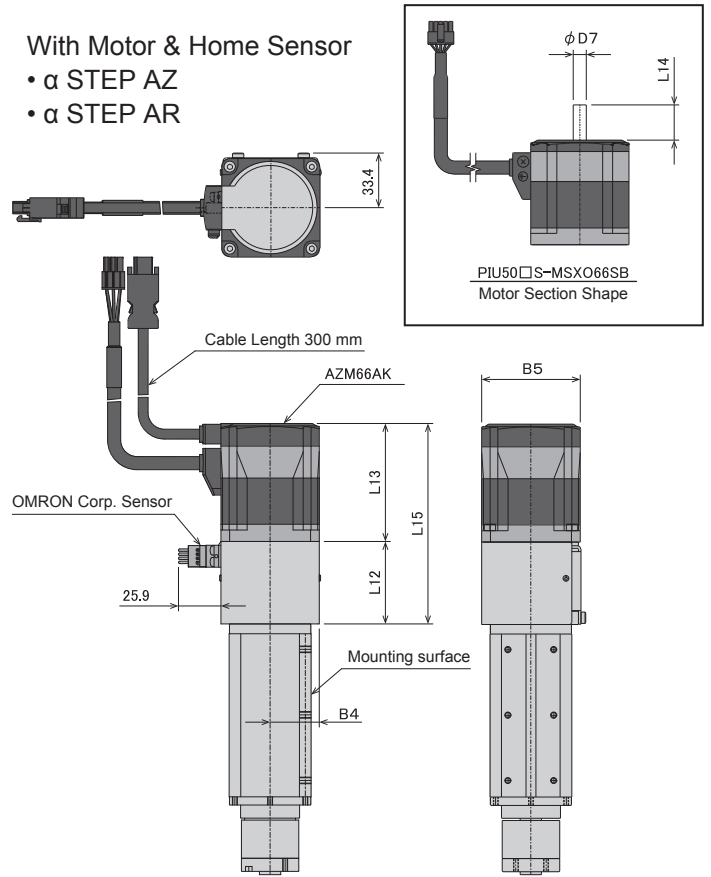

### α STEP AZ

Model No.	Length				Diameter D7	Width	
	L12	L13	L14	L15		B4	B5
PIU50□S-MSXOZ66AK	50.3	72	-	122.3	-	30	60

### α STEP AR

Model No.	Length				Diameter D7	Width	
	L12	L13	L14	L15		B4	B5
PIU50□S-MSXO66SB	50.3	64	21.5	135.8	8	30	60

\* PIU50□ accepts sizes 30 and 50.

\* Motor section protrudes beyond mounting surface. Ensure no interference during installation.



## Direct Motor Type (PIU50)

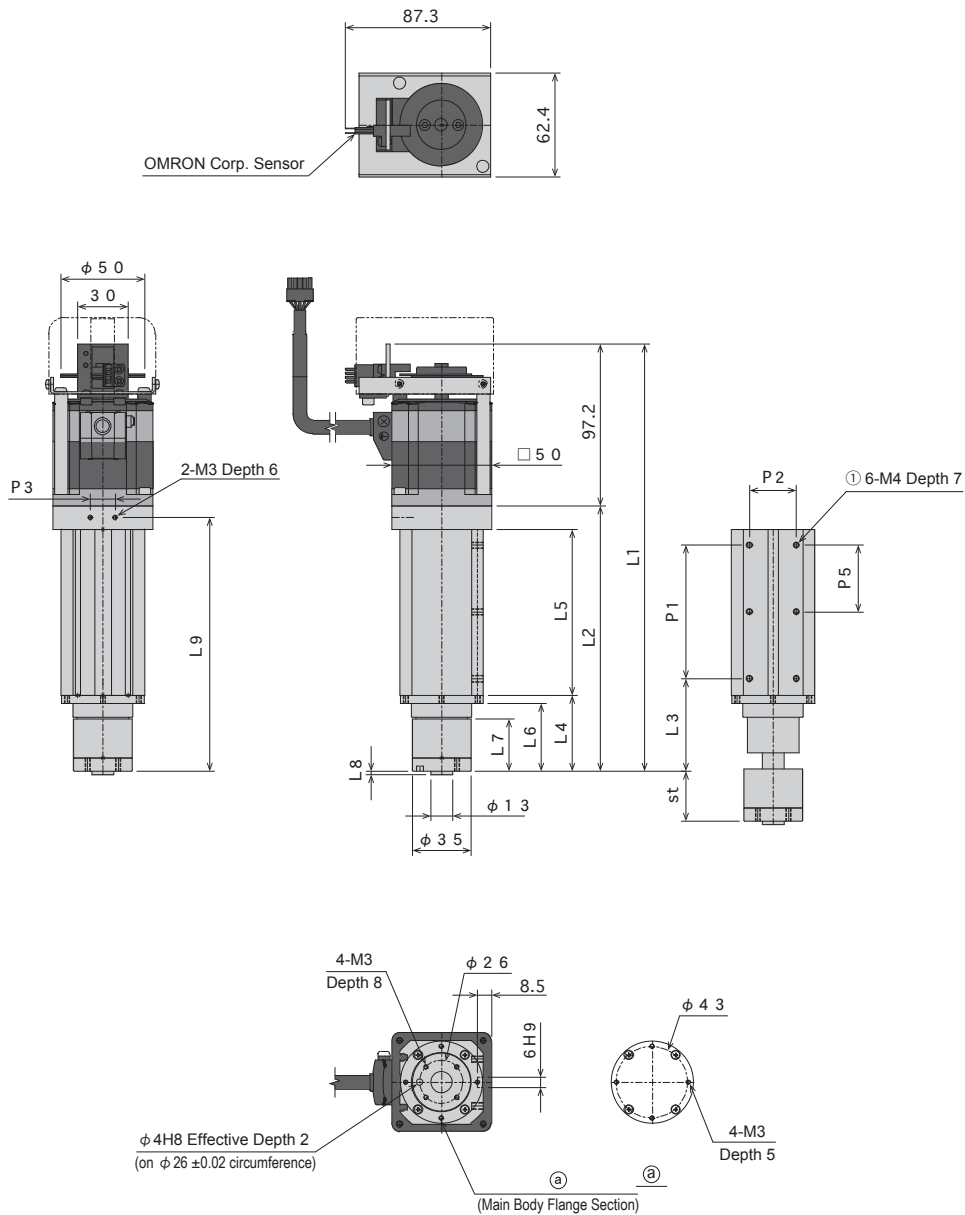

## $\alpha$ STEP AR Motor

Model No.	Stroke	Length									Pitch				
		st	L1	L2	L3	L4	L5	L6	L7	L8	L9	P1	P2	P3	P4
PIU5030DMX66S	30	256.2	159	55.5	45.5	99.5	40.5	31.3	2	152	80	28	15	30	40
PIU5050DMX66S	50	296.2	199			140				192					

\* CAD data is available.

\* See operation confirmation sensor on P-13.

\* Motor section protrudes beyond mounting surface. Please ensure no interference during installation.

# Chuck Holder Option

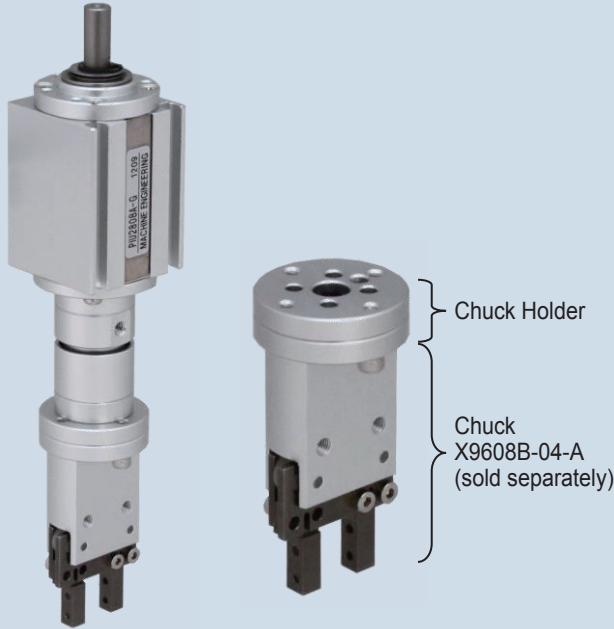

Holder prepared for mounting the Economy Type Parallel Open/Close Chuck X9608B-04 onto the 28 mm pick-up unit with air port. Enables easy workpiece gripping

- Air piping can be taken from the fixed air port on the Pick-up Unit.
- Chuck mounting orientation can be rotated by 90°.

### Applicable PIU Models

Stroke	External Input Type	Direct Motor Type
4	PIU2804A	PIU2804DM(X)□□A
8	PIU2808A	PIU2808DM(X)□□A
12	PIU2812A	PIU2812DM(X)□□A
16	PIU2816A	PIU2816DM(X)□□A
20	PIU2820A	PIU2820DM(X)□□A

### How to read product code

**PIU2804A-E-□-BK08B**

PIU Product Model

Chuck Holder  
BK08B: For X9608B-04  
(Chuck sold separately)

Chuck Holder Weight: 10g

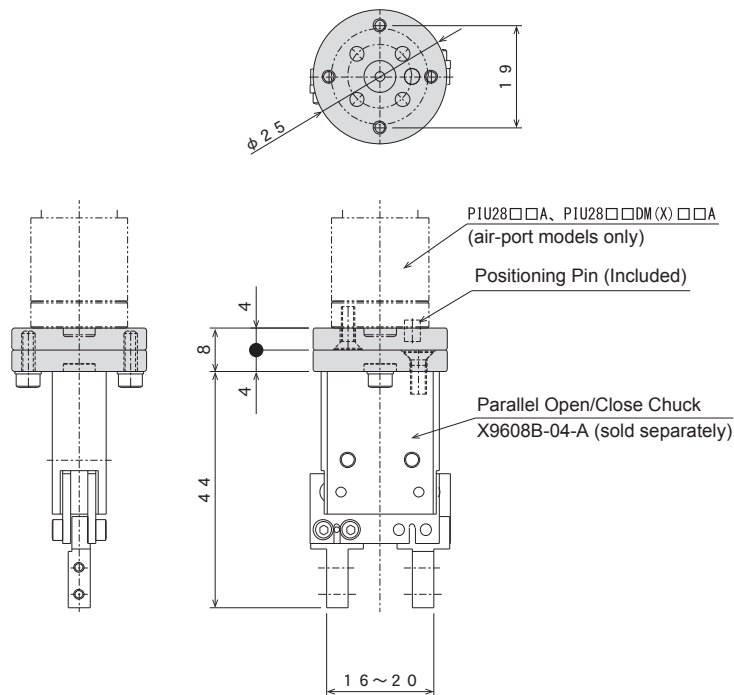



# Auxiliary Guide Option (Compatible with PIU Ball Bushing Guide)

## Position Detection Photo Sensor

High-precision detection is possible with a photo micro sensor.

## PIU Pick Up Unit

Combining with the ball-bush(B) type achieves high rigidity.

## Base Plate

Installation orientation can be freely changed in 90° increments.

## Ball Bushing Guide

Smooth operation with a ball-bush guide; it can handle high-speed work as well.

**Dual-axis guide provides strong lateral load resistance and high-precision support!!**

## High Lateral Load / High-Precision Support

Use when external load is applied or for high-precision transfer.

### Usage Examples

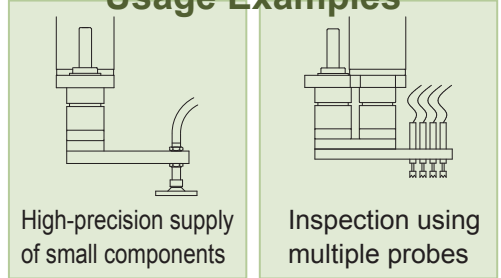

### Variations

Stroke (mm)	Compatible PIU models	
	External Input Type	Direct Motor Type
4	PIU2804B	PIU2804DM□□B
8	PIU2808B	PIU2808DM□□B
12	PIU2812B	PIU2812DM□□B
16	PIU2816B	PIU2816DM□□B
20	PIU2820B	PIU2820DM□□B
12	PIU4212B	PIU4212DM□□B
20	PIU4220B	PIU4220DM□□B

### How to read the product code

**PSG2808BC-S**

Auxiliary Guide

PIU basic model

Guide Shaft Specification

Position Detection Photo Sensor

2804B  
2808B  
2812B  
2816B  
2820B  
4212B  
4220B

No symbol: Solid Shaft  
C: Hollow Shaft

No symbol: None  
S: Included  
Sensor model: PM-U25-R  
\* For details, see P-21  
(Home sensor specifications).

PIU Ball Bushing type  
(Sold separately)

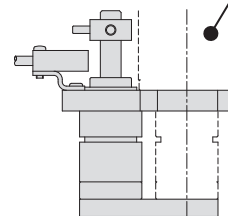

### Simple Setup

Mounting to the Pick-up Unit is easily set up using screw fastening.

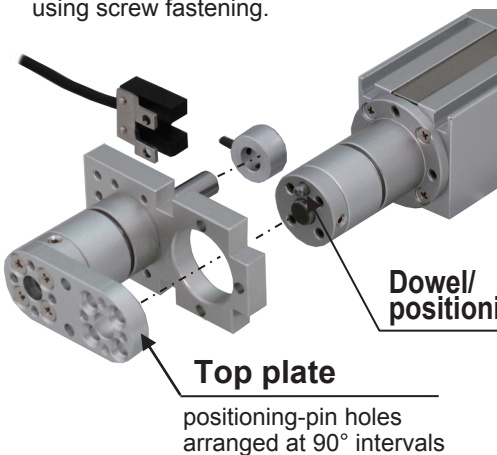

### Free Assembly Direction

Depending on equipment specifications, mounting can be freely changed in 90° increments.

### Free Sensor Mounting Direction

Depending on equipment specifications, the photo sensor mounting position can also be changed.

### Hollow Shaft Available

Can be used as an air port.

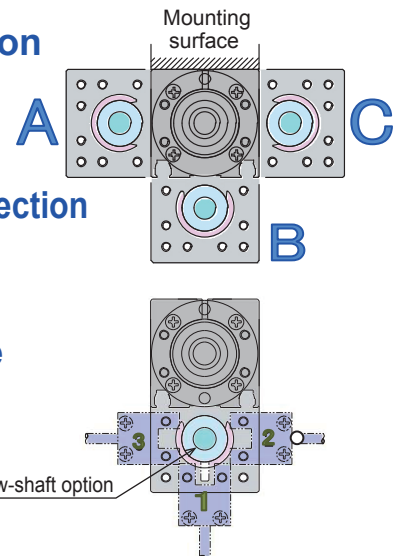

### Overhang Load Capacity

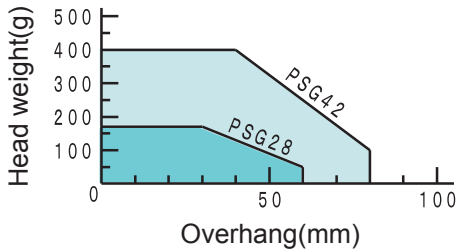

- \* The head mass refers to the weight mounted on the top plate.
- \* The reference point for overhang is the 'origin point' shown in the dimension diagram.

### Dimensions

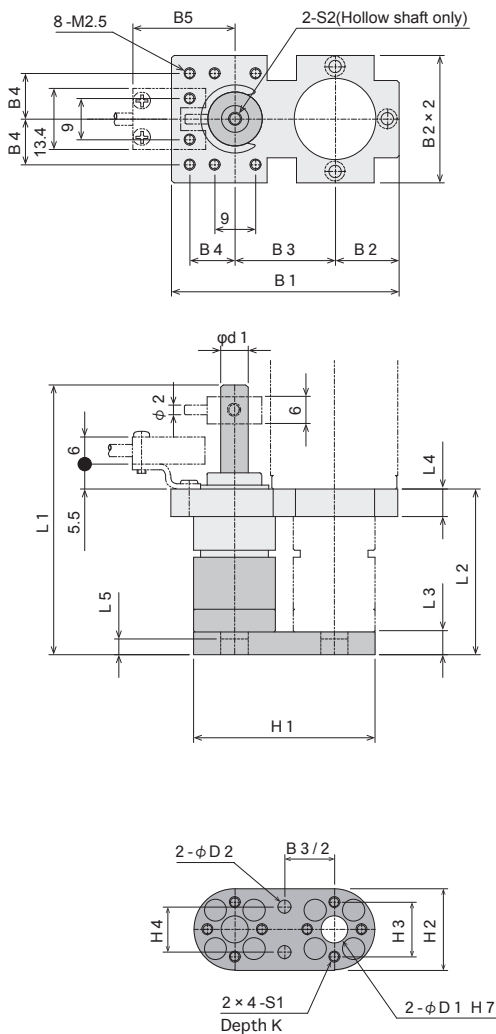

### Weight (Auxiliary Guide Only) (g)

Model	PSG						
	2804	2808	2812	2816	2820	4212	4220
Without Sensor	49	58	64	70	76	184	211
With Sensor	64	73	79	85	91	201	228
Movable Mass	27	30	33	35	39	87	102

- \* Pick-up Unit body weight not included.
- \* Movable mass includes the dog.

### Sensor Specifications

Sensor Name	Photo-micro Sensor
Model (Manufacturer)	PM-U25-R (Panasonic)
Dog	Light-shielding dog (Light ON)
Power Supply Voltage	DC5V-24V ±10% (Ripple P-P 10% or less)
Current Consumption	15mA or less

Model No.	Length					H1	H2	H3	H4
	L1	L2	L3	L4	L5				
PSG2804	47.5	28.5	5	6	3.5	40	18	12	12
PSG2808	59.5	36.5							
PSG2812	71.5	44.5							
PSG2816	83.5	52.5							
PSG2820	95.5	60.5							
PSG4212	78	50	6	8	4	62	28	20	18
PSG4220	102	66							

Model No.	Diameter					Taps					
	B1	B2	B3	B4	B5	D1	D2	d1	S1	S2	K
PSG2804	50	14	22	10	22.5	6	3	6	M2.5	M3	3
PSG2808											
PSG2812											
PSG2816											
PSG2820											
PSG4212	74	21	34	15	27.5	10	4	10	M3	M5	5
PSG4220											

### Notes (PSG)

- Ensure the PIU body is mounted so the top plate and baseplate do not tilt. Tilting may increase friction and cause malfunctions.
- If mounted on the side of the PIU body, the operation confirmation sensor cannot be attached.
- Do not use the sensor dog as a stopper.
- If fastening screws for the baseplate are insufficiently tightened, the internal guide's alignment may shift and cause malfunction.
- A hollow shaft is provided and may be used as an air port. Seal the unused top plate hole with tape.

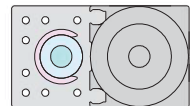

	Recommended tightening torque(N·m)
PSG28	0.5
PSG42	1.0

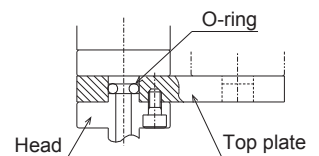



# Motor Bracket – Option



This bracket allows customers to mount their own motors onto the Pick-up Unit. It is compatible with the external input type and  $\theta$ -axis [PRB28] option of the Pick-up Unit.

- Using the motor bracket makes custom motor installation easier.
- Available in □28 mm and □42 mm sizes.
- A photo micro sensor-compatible model (MOB2) is also available for rotational position detection.
- The motor installation area is large, allowing flexible motor mounting.
- The Pick-up Unit and motor bracket can be rotated in 90° increments during installation.

## Variations

Applicable PIU models		General Type	Photo Sensor Type
PIU External Input type	PIU28	MOB1	MOB2
	PIU42		
$\theta$ -axis option	PRB28		
	PRB42		

## How to read product code

**PIU28-MOB1**

Pick Up Unit

Motor bracket

Body size

28 : □28mm  
42 : □42mm

MOB1 : General Type

MOB2 : Photo Sensor Type

〔Please prepare the photo sensor and dog on the customer side.〕



MOB2 sensor mounting example

## Basic Specifications

Model	General Type		Photo Sensor Type	
	PIU28-MOB1	PIU42-MOB1	PIU28-MOB2	PIU42-MOB2
Shape				
Accessories	M2.6×5L 8-piece	M3×6L 8-piece	M2.6×5L 8-piece	M3×6L 8-piece
Compatible photo sensor models	-	-	PM-R25(Panasonic)	
Product mass(g)	60	120	79	140

Note 1: Please prepare the sensor dog on the customer side based on the reference drawing.

Note 2: Please select and prepare the coupling on the customer side.

Note 3: Please select and prepare the motor on the customer side.

Note 4: Assembly of the Pick-up Unit and motor bracket should be done by the customer.

Note 5: The reference pin is used to prevent a large misalignment between the motor shaft center and the Pick-up Unit shaft center.

**Motor Dimensions**

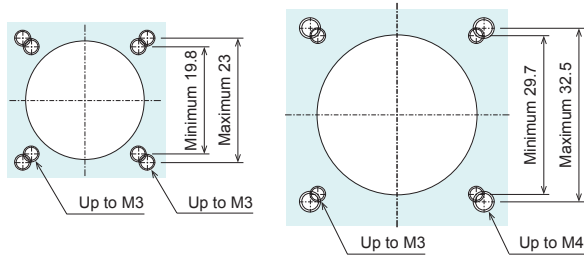

PIU28-MOB1

PIU42-MOB1

**Photo Sensor Dog – Reference Drawing**

\* Please prepare the sensor dog yourself, using the diagrams below.

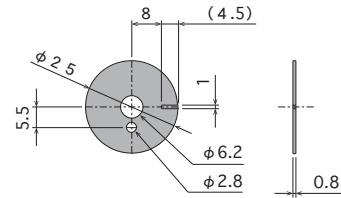

For PIU28-MOB2

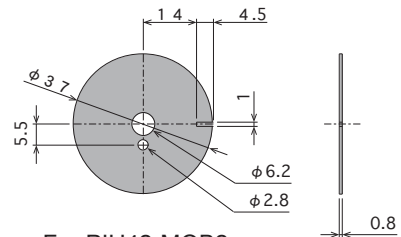

For PIU42-MOB2

**Dimension Drawing**

MOB1

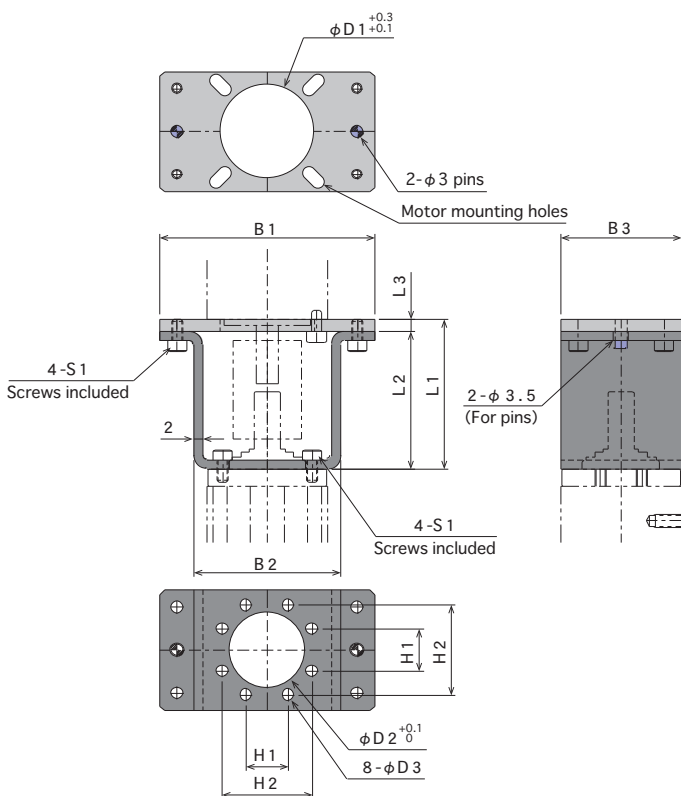

MOB2

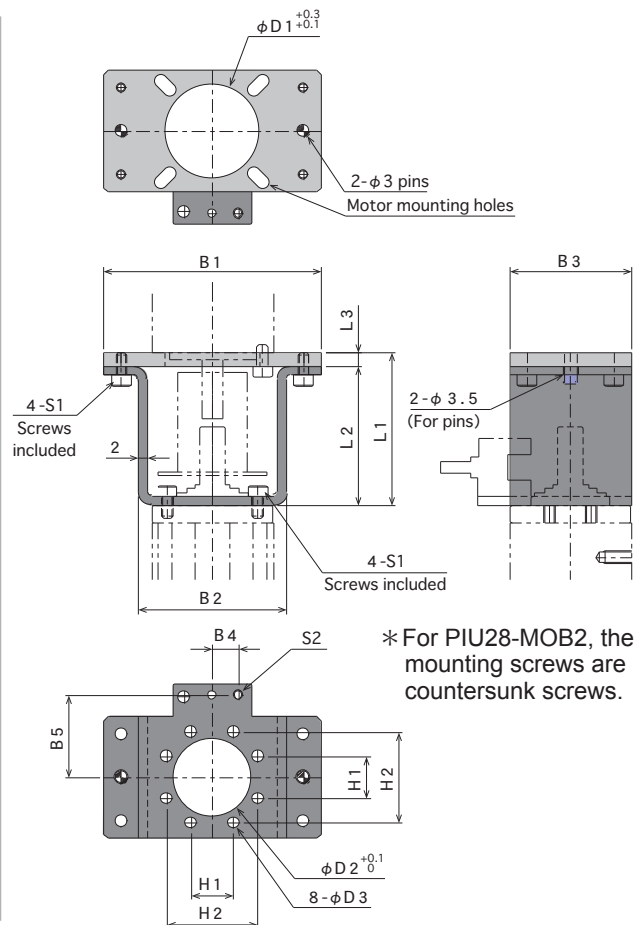

\* For PIU28-MOB2, the PIU mounting screws are countersunk screws.

	B1	B2	B3	B4	B5	L1	L2	L3	H1	H2	D1	D2	D3	S1	S2
PIU28-MOB	50	34	28	6	19	35	32	3	9.7	20.9	22	18	2.9	M2.6	M2.6
PIU42-MOB	64	48	42	6	25	49	44	5	15	32.2	30	28	3.5	M3	M2.6



# θ-Axis Option

(PRB Ball Spline Joint Type)

## Backlash-Free Rotation

### Theta Input Shaft

Used with stepping motor and Home sensor. Enables lightweight, high-speed rotation via direct connection to the head.

### Backlash Free Joint

Achieves highly accurate rotation by eliminating backlash. (Models with □50 head have slight backlash.)

### Built-In Air Circuit (Single Circuit)

Allows flexible routing because air piping enters through the rotation head.



\* Use by combining the θ-axis option with the Pick-up Unit. (Pick-up Unit sold separately)

The θ-axis option and Pick-up Unit can be ordered as a single combined model number; please see P-31.



θ-axis without motor  
External-input type  
combination example

θ-axis with αSTEP motor  
PIU direct type combination example

Pick-up Unit Assembly Example

### How to read product code

**PRB 2808 - C - MSO Z24AK - P**

PIU Base Models	Air Circuit Specification	With Motor	Motor Code	Precision Grade (Head Runout)
2808: For PIU2808 2812: For PIU2808 2816: For PIU2808 2820: For PIU2808 4212: For PIU2808 4220: For PIU2808 5030: For PIU2808 5050: For PIU2808	C: For Air chuck V: For Vacuum	M S O: With motor + Home sensor (Panasonic) MSXO: With motor + Home sensor (Omron)	For PRB28 Z24AK: with AZM24AK 24SB: with ARM24BK For PRB42 Z46AK: with AZM46AK 46SB: with ARM46BK For PRB50 Z66AKPS10 : with AZM66AK-PS10 66SAPS10 : with ARM66SAK-PS10	No symbol: Standard P: High Precision *□50 and above support only standard grade.

- \* PRB28 requires a chuck holder. Attach suffix "-BK08B" to the product code.
- \* Choose motor driver and cable separately. Consult us regarding motor configuration.
- \* Theta axis + Home sensor specifications → P12~13.
- \* For Pick-up Units, ball spline (S) is recommended.
- \* Pick-up Unit sold separately.



Usage examples

# θ-Axis Option

## Basic Specifications – PRB (Ball Spline Joint Type)

θ-axis model No. (Note.5)	PRB2808-■	PRB2812-■	PRB2816-■	PRB2820-■	PRB4212-■	PRB4220-■	PRB5030-■	PRB5050-■	
PIU Target model (Note.1)	External input type	PIU2808S	PIU2812S	PIU2816S	PIU2820S	PIU4212S	PIU4220S	PIU5030S	PIU5050S
	Direct Motor Type	PIU2808DM(X)24S	PIU2812DM(X)24S	PIU2816DM(X)24S	PIU2820DM(X)24S	PIU4212DM(X)46S	PIU4220DM(X)46S	PIU5030DMX66S	PIU5050DMX66S
Rotation angle	Unlimited								
Head stroke (maximum)	8.5mm	12.5mm	16.5mm	20.5mm	12.5mm	20.5mm	30.5mm	50.5mm	
Positioning accuracy (Note.7)	Standard: within 0.03°, High accuracy type: within 0.015°								
θ-axis backlash	None (Note.2)								
Rotation backlash	External Input type(Moter option available)								
Rotation detection method	None (Home-position photo sensor option available)(Note.6)								
Air supply method	For positive pressure (chuck) / for negative pressure (vacuum suction)								
Ambient temperature	10°C to 40°C								
Grease	Lithium-based, no relubrication required								
Weight (θ-unit body only)(Note.3)	145 (350) g	145 (350) g	160 (365) g	160 (365) g	419 (940) g	383 (940) g	1070 (2620) g	1190 (2740) g	
θ + PIU combined mass(Note.4)	424g	440g	472g	501g	1273g	1328g	3120g	3480g	
Head mass (vertical + θ)	60g	60g	60g	60g	203g	167g	370g	390g	

Note 1. When combining PIU with a θ-axis, the allowed orientation may be restricted depending on specifications. Details: P-37.

Note 2. Stopping accuracy depends on the motor's standstill angle error.

Note 3. Values in parentheses ( ) indicate with motor (same for AZ and AR).

Note 4. PIU combined mass is the mass of PIU28□DM(X)24S, PIU42□DM(X)46S, or PIU□50DMX66S plus the θ-axis unit alone.

Note 5. In the model No., a symbol is added after ■: "C" for positive pressure, "V" for negative pressure.

Note 6. The optional sensor dog has a detection hole with 1 mm width. Photo sensor details: P-14

Note 7. When the Pick-up Unit is ball spline (S).

## Operation Description

\* The θ-axis option must be used together with a Pick-up Unit. (Pick-up Unit sold separately)

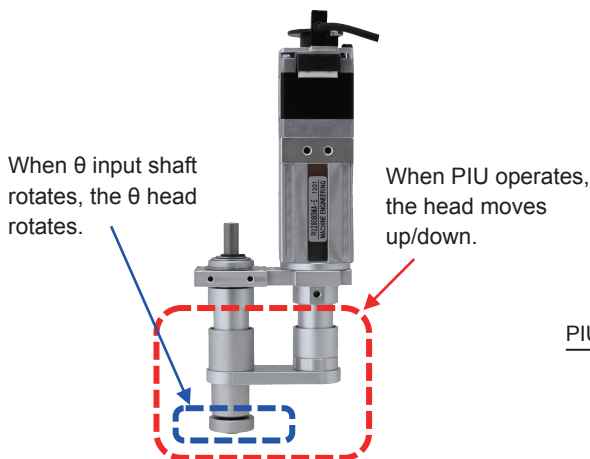

## Basic Dimensions

Body size	□28mm	□42mm	□50mm
Head allowable load (R)	30mm	50mm	120mm
Head allowable load (L)	50mm	100mm	150mm
Maximum head weight (W)	100g	250g	1000g

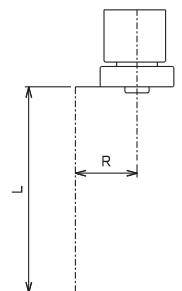

Head Maximum dimensions

## PIU+θ Combination Directions

You can select A, B, or C combination patterns. (Some restrictions may apply for pattern B.) Details: P-35

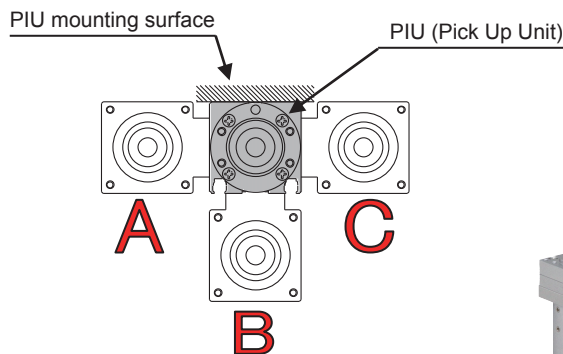

(Mounting direction A)



**Rotation Time and Head Size**

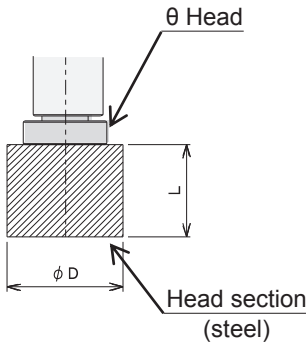

- Based on optional motor usage.
- For horizontal installation.
- With no external load or resistance.
- Acceleration/deceleration time is half of total rotation time.

**PRB28□  
PRH28 A**

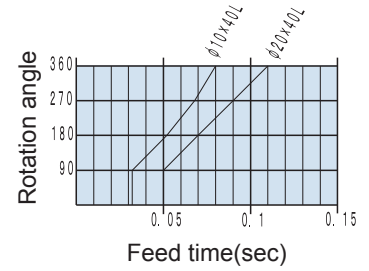

**PRB42□**

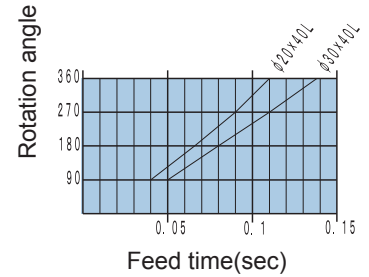
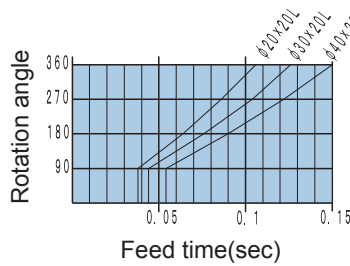

**PRB50□**

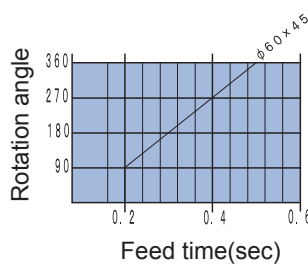

**PRB28□  
PRH28 A**

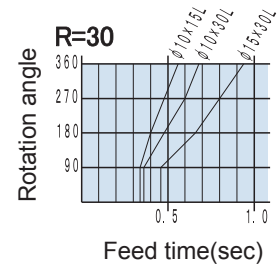
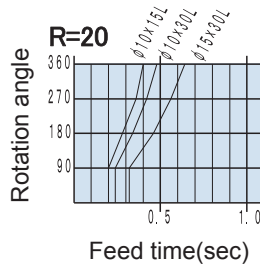

**PRB42□**

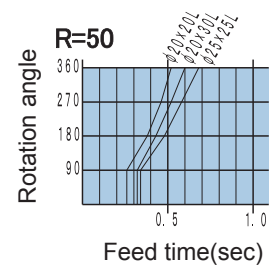
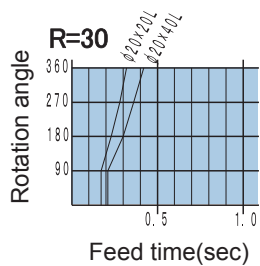

**PRB50□**

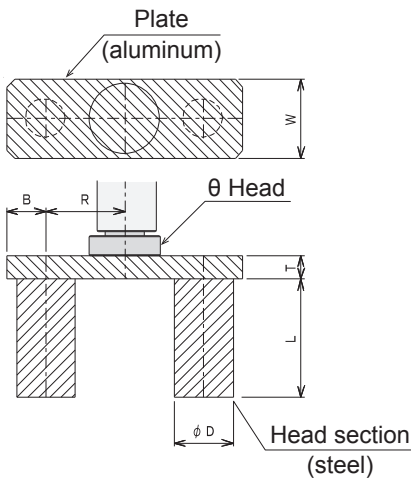
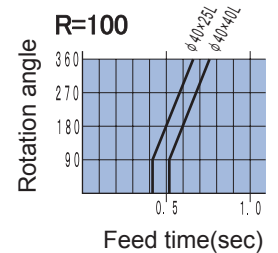
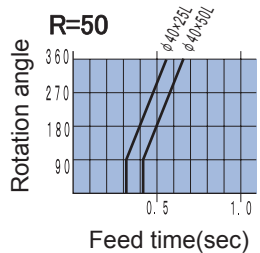

	T	B	W
PRB28	6	10	20
PRB42	6	15	30
PRB50	8	20	40

- Based on optional motor usage.
- For horizontal installation.
- With no external load or resistance.
- Acceleration/deceleration time is half of total rotation time.

# θ-Axis Option

## Dimensional Drawings (PRB28, PRB42)

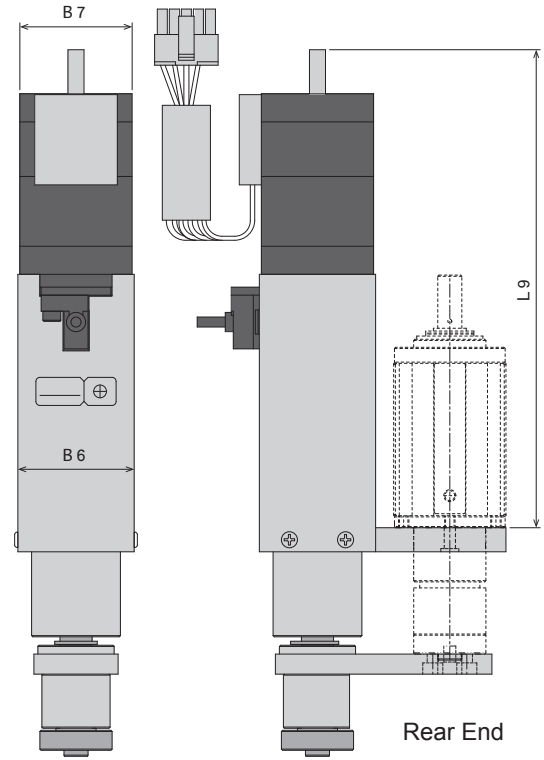
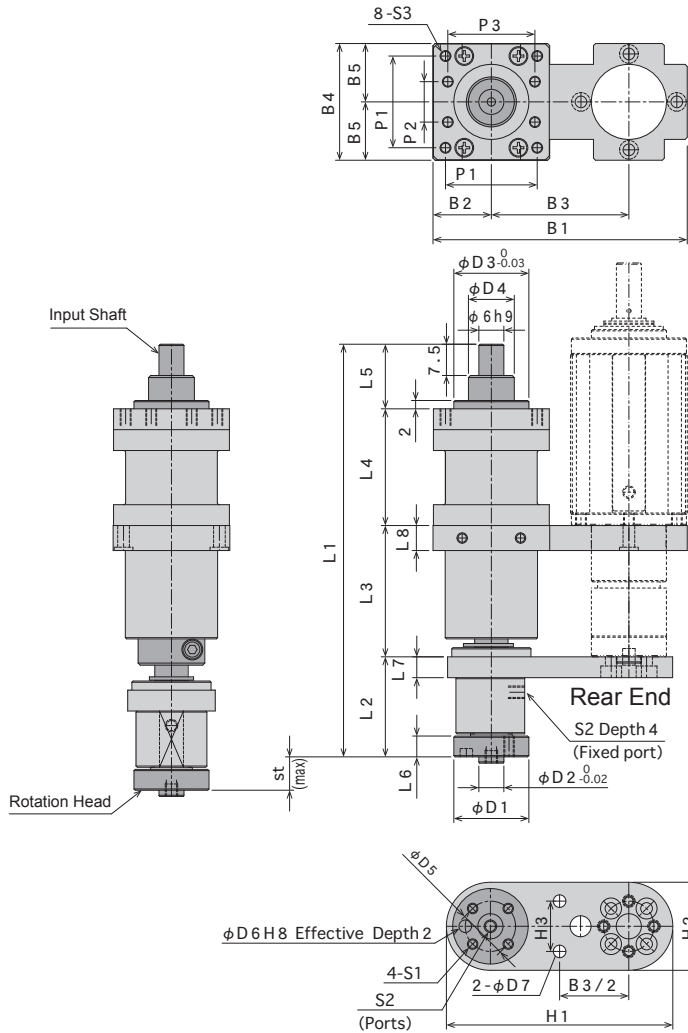

- \* Panasonic-made Sensor (MSO) shown in illustration
- \* Pick-up Unit mounting direction selectable in 3 directions

### With αSTEP motor

Model No.	Stroke	Length								Width				
	st	L1	L2	L3	L4	L5	L6	L7	L8	B1	B2	B3	B4	B5
PRB2808	8	99	24	31.5	28	15.5	5	5	6	61	14	33	28	14
PRB2812	12	107	24	39.5	28	15.5	5	5	6	61	14	33	28	14
PRB2816	16	106	24	55.5	11	15.5	5	5	6	61	14	33	28	14
PRB2820	20	106	24	55.5	11	15.5	5	5	6	61	14	33	28	14
PRB4212	12	124.5	36	60	15	13.5	6	8	8	96.8	21	55	42	21
PRB4220	20	124.5	36	60	15	13.5	6	8	8	96.8	21	55	42	21

Model No.	Diameter							Pitch			Taps					
	D1	D2	D3	D4	D5	D6	D7	P1	P2	P3	H1	H2	H3	S1	S2	S3
PRB2808	18	6	18	11	12	3	3	22	9.7	20.9	54	21	12	M2.5	M3	M2.6
PRB2812	18	6	18	11	12	3	3	22	9.7	20.9	54	21	12	M2.5	M3	M2.6
PRB2816	18	6	18	11	12	3	3	22	9.7	20.9	54	21	12	M2.5	M3	M2.6
PRB2820	18	6	18	11	12	3	3	22	9.7	20.9	54	21	12	M2.5	M3	M2.6
PRB4212	28	10	28	13	20	4	4	31	15	32.17	89	34	20	M3	M5	M3
PRB4220	28	10	28	13	20	4	4	31	15	32.17	89	34	20	M3	M5	M3

	Model No.	L9	B6	B7
	A Z	PRB2808-MS(X)OZ24AK	118	29
PRB2812-MS(X)OZ24AK		118	29	28
PRB2816-MS(X)OZ24AK		101	29	28
PRB2820-MS(X)OZ24AK		101	29	28
A R	PRB42□-MS(X)OZ46AK	120	42	42
	PRB2808-MS(X)O24SB	119	29	28
	PRB2812-MS(X)O24SB	119	29	28
	PRB2816-MS(X)O24SB	102	29	28
	PRB2820-MS(X)O24SB	102	29	28
	PRB42□-MS(X)O46SB	133	42	42

\* CAD data is available. Please contact us.



## Dimensional Drawings (PRB50)

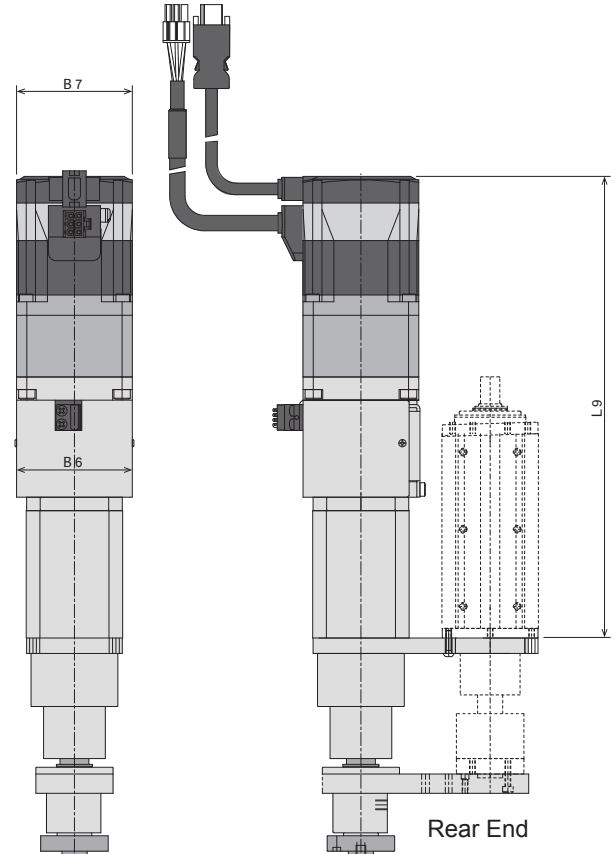
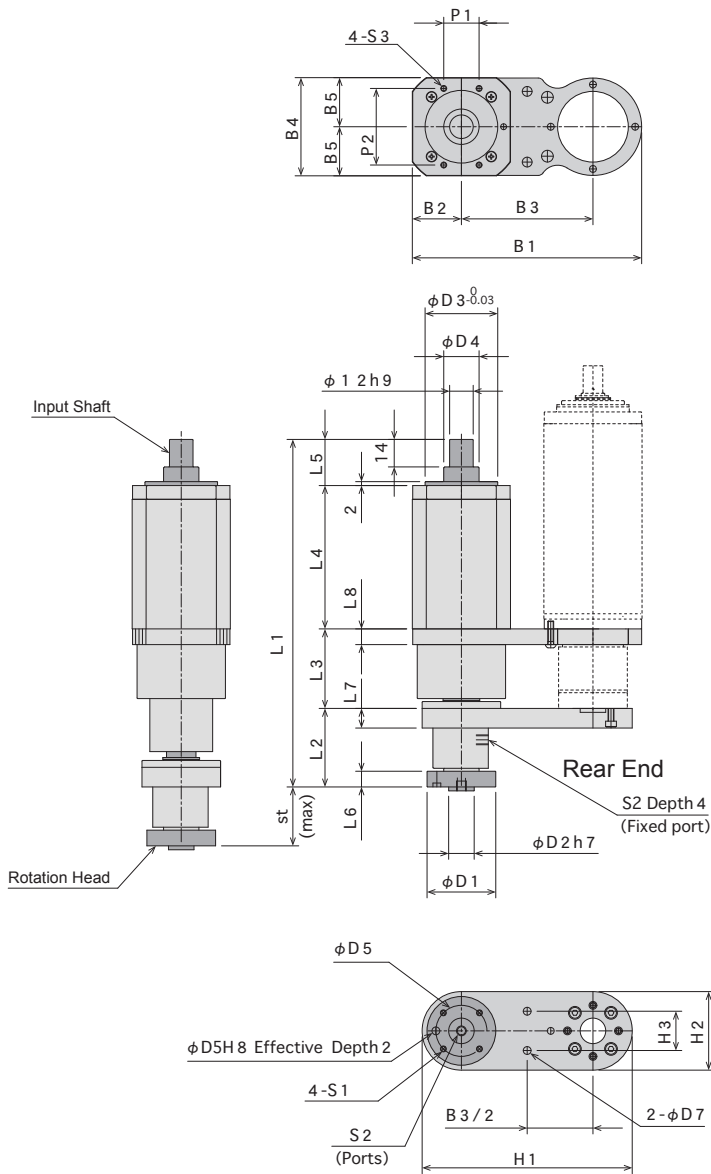

- \* Omurion -made Sensor (MSXO) shown in illustration
- \* Pick-up Unit mounting direction selectable in 3 directions

**With αSTEP motor**

Model No.	Stroke	Length								Width				
		st	L1	L2	L3	L4	L5	L6	L7	L8	B1	B2	B3	B4
PRB5030	30	177	40	40.5	73	23.5	8	10	8	116.8	25	67	50	25
PRB5050	50	197	40	40.5	93	23.5	8	10	8	116.8	25	67	50	25

Model No.	Diameter							Pitch		Taps					
	D1	D2	D3	D4	D5	D6	D7	P1	P2	H1	H2	H3	S1	S2	S3
PRB5030	35	13	37	18	26	4	4	18	39	107	40	20	M3	M5	M3
PRB5050	35	13	37	18	26	4	4	18	39	107	40	20	M3	M5	M3

Model No.		L9	B6	B7
A	PRB5030-MSXOZ66AKPS10	239	60	60
Z	PRB5050-MSXOZ66AKPS10	259	60	60
A	PRB5030-MSXO66SAPS10	231.8	60	60
R	PRB5050-MSXO66SAPS10	252	60	60

\* CAD data is available. Please contact us.

# Swivel Arm & Rotary Head Options

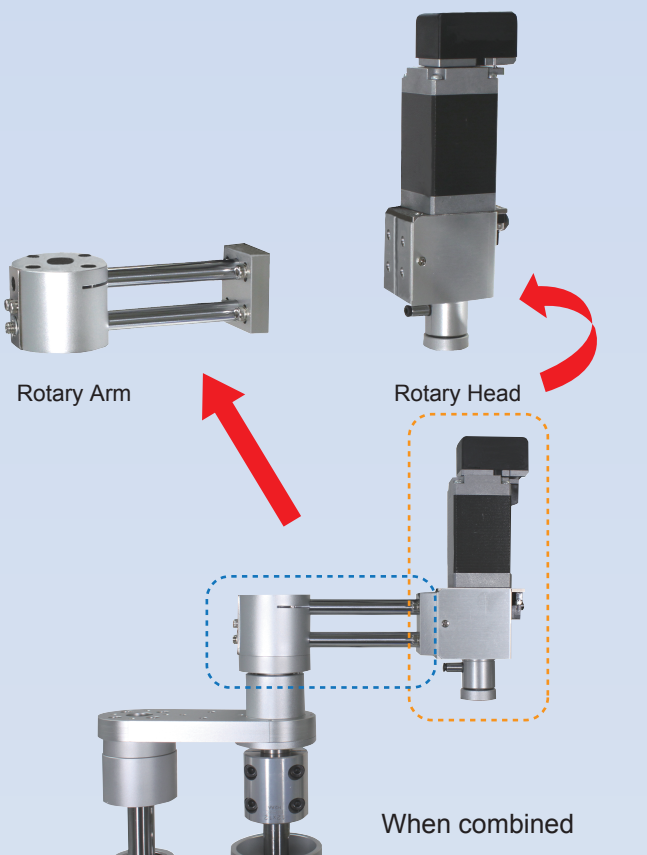

- A swivel arm compatible with the □50 mm Pick-up Unit has been prepared.
- Using a cam mechanism for vertical movement, an oscillating transfer unit can be configured.
- The rotary head has an internal air circuit to reduce piping load.

### Swivel Arm Mass (g)

PRA50		
A060	A080	A100
126	134	142

### Basic Specifications (Rotary Head)

Model No. (Note.1)	PRH28A-■
Rotation Angle	Unlimited
Backlash	None (Note 2)
Rotational Vibration Precision	Within 0.03 mm
Drive Method	Stepper Motor
Home Sensor	Photomicro Sensor
Air supply method	For positive pressure (chuck) / for negative pressure (vacuum suction)
Ambient temperature	10~40°C
Product mass (Note.3)	276g

Note 1: ■ in the model No. contains a symbol: "C" for positive pressure, "V" for negative pressure.  
 Note 2: Stopping accuracy depends on the motor's standstill angle error.  
 Note 3: Mass values are with αSTEP AZ motor.  
 \*For transfer weight and feed time, see P-26.

### How to read product code

Swivel Arm

**PRA50-A100**

Swivel Arm  
 PIU body size: 50 : □50mm  
 Arm specification: A: First arm  
 Arm length: 060 : 60mm, 080 : 80mm, 100 : 100mm

Rotary Head

**PRH28A-C-Z24AK**

Rotary Head  
 PRH body size: 28A : □28mm  
 Air circuit specification: C: For air chuck, V: For vacuum  
 Motor Code: α STEP AZ, Z24AK : AZM24AK, Z26AK : AZM26AK, α STEP AR, 24SB : ARM24SBK, 2-Phase Stepping, 23DB : PKP223D15B2

### Rotary Head Sensor Specifications

Sensor Name	Photomicro sensor
Model	PM-R25-R
Manufacturer	Panasonic
Dog	slit dog
Power supply voltage	DC 5 to 24 V ±10% [Ripple (P-P) 10% or less]
Current Consumption	15 mA or less
Indicator	Lights when receiving light (LED)
Cable length	1m

\*For circuit diagram, see P-13.

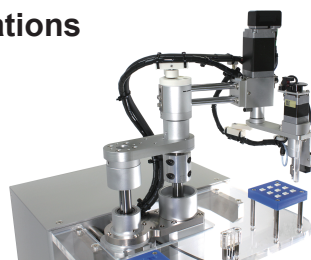

Usage examples

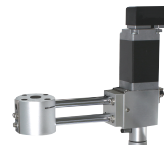

## Dimensional Drawings

### PRA – Swivel Arm

2- $\phi 3.5$  drilled holes  
 $\phi 6.5$  deep counterbore  
 depth 3.3

2- $\phi 3.5$

2-M4 depth 8  
 (Service tap)

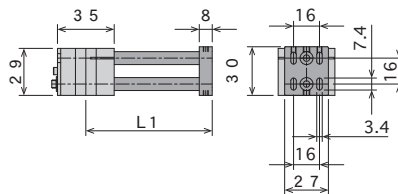

Model No.	Length
PRA50-A060	L1 60
PRA50-A080	80
PRA50-A100	100

### PRH – Rotary Head with AZM26AK

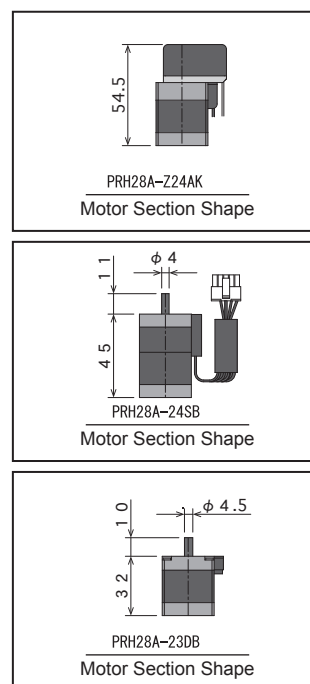
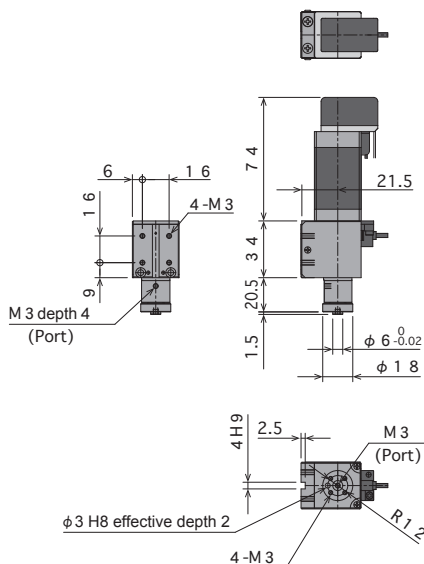

### Assembly Examples (PRA + PRH)

#### 【Example 1】

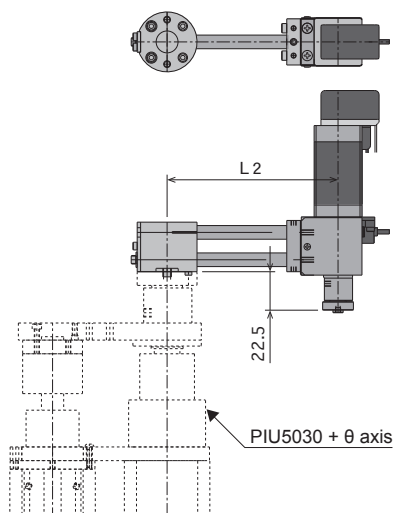

#### 【Example 2】

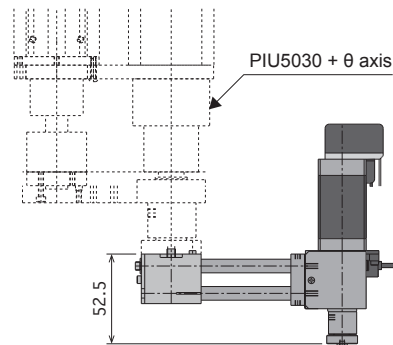

Swivel Arm Model No.	Length L2
PRA50-A060	82
PRA50-A080	102
PRA50-A100	122

# PIU-θ axis combined model designation

When purchasing the PIU and θ-axis option, specify using the model format below.

Model Shaft Cam Sensor θ-axis specification PIU Motor θ-axis Motor Option  
**PIRB2808S-F-SSZ13A-CPA-MSZDB-MSZDB-** □

① ② ③ ④ ⑤ ⑥ ⑦ ⑧ ⑨ ⑩ ⑪ ⑫ ⑬ ⑭ ⑮ ⑯ ⑰ ⑱~

① Body size and basic stroke      ② Shaft specification      ③ PIU cam specification

Code	Size	Stroke	A	B	S
2808	□28	8mm	●	●	●
2812		12mm	●	●	●
2816		16mm	—	●	●
2820		20mm	—	●	●
4212	□42	12mm	●	●	●
4220		20mm	●	●	●
5030	□50	30mm	—	—	●
5050		50mm	—	—	●

Code	Cam specification-free
E	Shockless 2-Position
F	Free Stroke
G	Forward End Position Adjustment
FR	Free-Stroke, Reverse Home Specification
GR	Forward End Position Adjustment Reverse Home Specification

\*FR and GR are supported only for □50.

● : Selectable  
 — : Not selectable

Code	② Shaft specification
A	With Air Port
B	Ball Bushing
S	Ball Spline

④ PIU Operation-confirmation sensor

Code	Number of sensors
N	No sensor
S	One sensor
SS	Two sensor



⑤ PIU operation-confirmation sensor specification

Code	Wiring method	Cable exit direction
Z13	2-wire	Axial Direction
Z23	2-wire	Right Angle Direction
Z15	3-wire(NPN)	Axial Direction
Z25	3-wire(NPN)	Right Angle Direction

\*If there is no sensor, ⑤ and ⑥ are left blank (no symbol).

⑥ Cable Length (Operation Confirmation Sensor)

Code	Cable Length
A	1m
B	3m

⑦ θ-axis Air Circuit Specification

Code	Air Circuit Type
C	For air chuck
V	For vacuum

⑧ Precision Grades (Head Runout)

Code	Grade	Runout
B	Standard	0.08
H	High Grade	0.03
P	Precision	0.015

\*High Grade/precision grade: Shaft specification: ball spline only supported  
 \*□50 is supported only for standard and high grades.

⑨ θ-axis Mounting Direction

Code	Mounting Position
A	Left-side mounting
B	Front mounting
C	Right-side mounting

\*There are restrictions on specifications that allow front mounting. Please check the table on the right.  
 \*Even if a combination is not possible, it may be supported as a special specification, so please contact us.

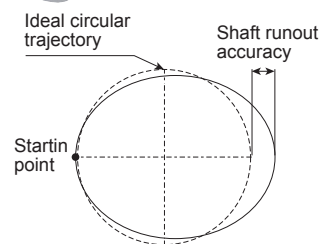
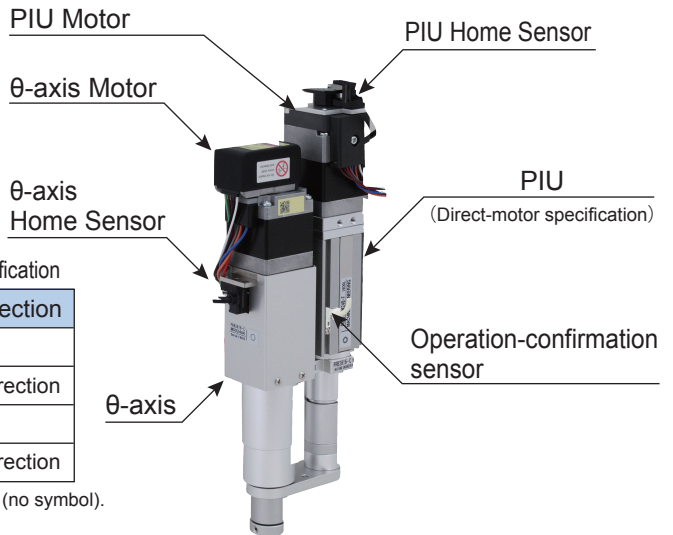
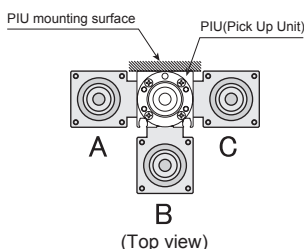

### θ Axis Mounting Direction B

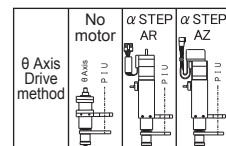

Pick Up Unit	Model Drive method	PRB28 **			PRB42 **			PRB50 **		
		No motor	α STEP AR	α STEP AZ	No motor	α STEP AR	α STEP AZ	No motor	α STEP AR	α STEP AZ
External Input	No motor	○	○	○	○	○	○	○	○	○
	With α STEP	AR	x	x	—	○	○	—	x	x
Direct Motor Type	AR	x	—	x	○	—	○	x	—	x
	AZ	x	x	x	x	x	x	x	x	x
With operation-confirmation sensor	AR	x	x	x	x	x	x	x	x	x
	AZ	x	x	x	x	x	x	x	x	x



### ⑩ PIU Motor Mounting Specification

Code	Motor Mount Specification
N	No motor
MS	Motor + Home sensor (Panasonic)
DM	Direct motor type + Home sensor (Panasonic)
MSX	Motor + Home sensor (Omron)
DMX	Direct motor type + Home sensor (Omron)

\*If there is no motor, ⑩⑪⑫⑬⑭ are left blank (no symbol)  
 \*Please check the table below for motor model numbers.  
 \*For □50, only N, MSX, and DMX can be selected.  
 \*If you want to change the motor cable exit direction, please contact us.

#### PIU motor compatibility table

Size	MS						DM						MSX						DMX					
	Z	R	P	Z	R	P	Z	R	P	Z	R	P	Z	R	P	Z	R	P						
□28	—	○	—	○	—	○	—	—	—	○	—	○	—	○	—	○	—	—	—	○	—	○		
□42	●	●	○	○	—	○	—	—	○	○	—	○	●	●	○	○	—	○	—	○	—	○		
□50	—	—	—	—	—	—	—	—	—	—	—	—	●	●	○	○	—	—	—	○	○	—		

● : Selectable / brake-equipped selectable  
 ○ : Selectable / brake-equipped not selectable  
 — : Not selectable

### ⑪ PIU Motor Specification

Code	Motor Type
Z	AZ Series (Oriental Motor)
R	AR Series (Oriental Motor)
P	PKP Series (Oriental Motor)

### ⑫ Motor Power Supply Specification

Code	Power Supply Type
A	AC Power
D	DC Power

### ⑬ PIU Electromagnetic Brake

Code	Brake Type
No symbol	Without brake
B	With brake

### ⑭ θ-axis Motor Mount Specification

Code	Motor Mount Specification
N	No motor
MS	Motor + Home sensor (Panasonic)
MSX	Motor + Home sensor (Omron)

\*If there is no motor, ⑮⑯⑰ are left blank (no symbol)  
 \*Please check the table below for motor model numbers.  
 \*For □50, only N, MSX can be selected.  
 \*If you want to change the motor cable exit direction, please contact us.

#### θ-axis motor compatibility table

Size	MS						MSX					
	Z	R	P	Z	R	P	Z	R	P	Z	R	P
□28	—	○	—	○	—	○	—	○	—	○	—	○
□42	●	●	○	○	—	○	●	●	○	○	—	○
□50	—	—	—	—	—	—	○	○	○	○	—	—

● : Selectable / brake-equipped selectable  
 ○ : Selectable / brake-equipped not selectable  
 — : Not selectable

### ⑮ θ-axis Motor Specification

Code	Motor Type
Z	AZ Series (Oriental Motor)
R	AR Series (Oriental Motor)
P	PKP Series (Oriental Motor)

### ⑯ θ-axis Motor Power Supply

Code	Power Supply Type
A	AC Power
D	DC Power

### ⑰ θ-axis Electromagnetic Brake

Code	Brake Type
No symbol	No brake
B	With brake

### Motor Model

Body	Motor type	DC power supply	AC power supply
□28	α STEP AZ	AZM24AK (Single shaft)	—
	α STEP AR	ARM24SBK (Double shaft)	—
	PKP	PKP223D15B2 (Double shaft)	—
□42	α STEP AZ	AZM46AK (Single shaft)	AZM46AC (Single shaft)
		AZM46MK (With brake)	AZM46MC (With brake)
	α STEP AR	ARM46SBK (Double shaft)	ARM46BC (Double shaft)
	PKP	PKP244D23B (Double shaft)	—
□50 (PIU)	α STEP AZ	AZM66AK (Single shaft)	AZM66AC (Single shaft)
		AZM66MK (With brake)	AZM66MC (With brake)
	α STEP AR	ARM66SBK (Double shaft)	ARM66BC (Double shaft)
	PKP	—	—
□50 (θ-axis)	α STEP AZ	AZM66AK-PS10 (Single shaft)	AZM66AC-PS10 (Single shaft)
	α STEP AR	ARM66SAK-PS10 (Single shaft)	ARM66AC-PS10 (Single shaft)
	PKP	—	—

⑱ Other Options

Other available options can be specified by selecting from item ⑱ onward as shown below.

(1) Chuck Holder (for □28 only)

- **BK08B**

⑱ Option Code

Code	Option
BK08B	With Chuck Holder



Chuck Holder

Chuck (sold separately):  
X9608B-04-A

(2) Swivel Arm & Head Options (for □50 only)

Swivel Arm                      Rotary Head  
 - **A50** - **100** - **H28** - **C** - **MZ**  
 ⑱                      ⑲                      ⑳                      ㉑                      ㉒

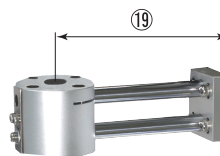

Swivel Arm

⑱ Option code

Code	Option
A50	With Arm

⑲ Swivel arm length

Code	Swivel arm length
060	60mm
080	80mm
100	100mm

⑳ Option code

Code	Option
H28	With Rotary head

㉑ Rotary head air circuit specification

Code	Air circuit specification
C	For air chuck
V	For Vacuum

㉒ Motor Specifications

Code	Motor Type	Motor Model
MZ	α STEP AZ (Oriental Motor)	AZM24AK
MZL	α STEP AZ Long Motor (Oriental Motor)	AZM26AK
MR	α STEP AR (Oriental Motor)	ARM24SBK
MP	PKP (Oriental Motor)	PKP223D15B2



Rotary Head

## ■ Notes on selection (PIU)

- Magnets are built into the product body. In environments that are sensitive to magnetic materials (e.g., iron powder accumulation, surrounding cylinder sensors, workpieces, etc.), please take care.
- Models without a motor do not have a home sensor on the input shaft.  
Install one as needed on the customer side.
- Please prepare the motor driver for motor-equipped models on the customer side.
- Please design and manufacture the chuck and vacuum pad on the customer side. For air chuck mounting, please contact us.
- The head operates as shown in the "operation timing diagram." E (continuous) can be used by rotating either CW or CCW, but F and G are used in reciprocating motion within 360° (720°).
- There are no restrictions on mounting orientation, but if used laid sideways, keep the sensor groove surface facing upward as much as possible.
- For the air-port type, if air is strongly blown out for purposes such as vacuum break, internal grease or moisture may scatter.
- For details on the operation-confirmation sensor, see the product guidebook. (MEPAC parallel open/close chuck, operation-confirmation sensors ZE255□ and ZE235□)
- Even if the operation-confirmation sensor is aligned to the upper/lower ends, it will turn "ON" for about a 2 mm travel region from the stroke end.
- The mounting direction (upper/lower end) of the operation-confirmation sensor for PIU28□B is as indicated in the dimensional drawing.
- High thrust is generated near the travel ends due to the cam curve.  
If the workpiece approach height varies, provide a buffer, etc., on the head.
- Stop the input shaft in the dwell section and constant-speed section.  
Stopping in the cam-curve region is not allowed except in emergencies.  
Starting from mid-travel can cause overload, leading to malfunction or early damage. (P-8 to P-9)
- Do not apply external rotational load to the head. If a load is applied in the rotational direction, install an anti-rotation guide. (Use it as needed.)(An auxiliary guide is available as an option. Details: P-20)

## ■ About home return (PIU)

### External-input type

- Motor & sensor-equipped models have a 1 mm wide slit dog for detecting the home position. Control it to stop at the position where this dog turns ON.
- The PIU2812/20 and PIU5050 types rotate more than 360°, so an home sensor must be used for the home return operation.
- For motor-equipped models, do not unnecessarily loosen the coupling screws. The home dog position may shift, causing interference, damage, or malfunction.
- The input shaft has a marking indicating the home position. The position shown in the right figure is the home position.

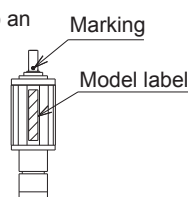

### Direct-motor type

- A dog with a  $\varnothing 1$  hole is attached for detecting the home position. Control it to stop at the position where this dog turns ON.
- The hole position of the home dog is preset. (Home position in P-8 to P-9)

## ■ Precautions for use (PIU)

- Before use, be sure to read the instruction manual carefully, and use the product correctly and safely.
- Perform wiring after confirming in the instruction manual.
- Also read the motor driver instruction manual, and use it with correct wiring.
- When using the operation-confirmation sensor, if there is a location where a strong magnetic field occurs nearby, apply magnetic shielding using steel plates, etc.
- Do not bring ferromagnetic materials (iron, etc.) near the operation-confirmation sensor. As a guideline, keep a distance of at least 10 mm.
- Install a safety cover on the drive section (input shaft).
- For mounting the product body, use tap holes ① in the dimensional drawing.  
A key groove is provided on the tapped surface; use it as a reference for repeatability.  
For external-input types with motor & home sensor, tap holes ② in the dimensional drawing are recommended.
- Do not hammer when inserting a key or pin into the key groove.
- For external-input type, connect the motor using a coupling, etc., and do not apply radial or thrust load to the input shaft.
- Do not operate during acceleration/deceleration zones while being transported by robots, etc. Unexpected inertial force may cause abnormal operation or early failure.
- Keep the motor surface temperature at 70°C or lower.
- For motor-equipped models, during continuous operation, stop at the home position for at least 100 ms.
- If motor-equipped models are used at ambient temperatures of 15°C or lower in the fastest performance region (as per the cycle time and allowable payload table), perform at startup warm-up (low-speed operation) for at least 10 minutes.
- Do not apply repeated loads such as bending or pulling to the sensor cable. Take measures to prevent such loads.  
In particular, so that no load is applied at the base of the sensor cable, secure the cable, etc.
- The home dog of the direct-motor type can be used as a manual handle. (It can be used for manual operation.) After turning off the equipment power, you can rotate it by hand to move the head forward/backward. Do not touch it during operation.
- The front tap holes (2-M3) on the direct-motor type can be used to mount cable clamps, etc., to secure wiring.

**Notes on selection ( $\theta$ -axis)**

- There are three combination types as shown in diagrams A, B, and C below.  
However, for type B, there are restrictions depending on PIU specifications as shown in the table below.

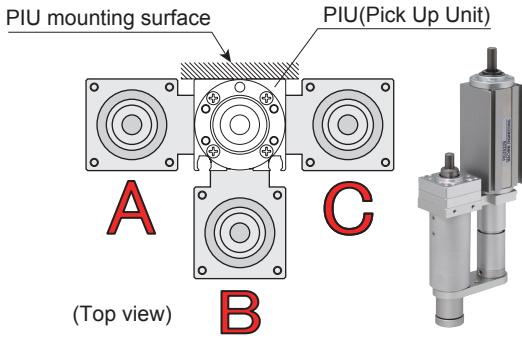

In the case of combination B

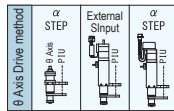

$\theta$ Axis	Model	PRB28 **			PRB42 **			PRB50 **		
	Drive method	No Motor	$\alpha$ STEP AR	$\alpha$ STEP AZ	No Motor	$\alpha$ STEP AR	$\alpha$ STEP AZ	No Motor	$\alpha$ STEP AR	$\alpha$ STEP AZ
Pick Up Unit	External Input No Motor	○	○	○	○	○	○	○	○	○
	External Input With $\alpha$ STEP (Note 2) AR	×	×	—	○	○	—	×	×	—
	External Input AZ	×	—	×	○	—	○	×	—	×
	Direct Motor Type	×	×	×	×	×	×	×	×	×
	With operation confirmation sensor	×	×	×	×	×	×	×	×	×

- Note 1: For A and C, all combinations are possible.
- Note 2: Combinations are AR with AR, and AZ with AZ.
- Note 3: For motor and sensor-equipped units, be careful of cable interference.
- Note 4: Even if a combination is not possible, it may be supported as a special specification, so please inquire.(Please contact us.)

• Product specifications and statements in this catalog may be changed without notice for product improvement.

**MACHINE ENGINEERING CORPORATION**

2380-480 Minamiminowa-mura, Kamiina-gun, Nagano 399-4583, Japan  
Tel: +81-265-76-0001 Fax: +81-265-76-9601

<https://www.meg.co.jp/en/>

E-mail : [d-sales@meg.co.jp](mailto:d-sales@meg.co.jp)